



Essenze di Luce®

**catalogo** catalogue

italiano english

04 AZIENDA COMPANY

- 06 chi siamo about us
- 08 il materiale the material
- 10 artigianalità craftsmanship
- 12 fatto in Italia made in Italy
- 14 progettazione degli spazi space design

16 COLLEZIONI COLLECTIONS

18 atmosfera atmosphere

- 22 MENHIR DI LUCE
- 30 MENHIR MINIMAL
- 38 MENHIR POOL
- 46 RAY



54 essenziale essential

- 58 STAKE
- 66 FOCUS
- 74 SOL
- 82 FLOR

90 audio audio

- 94 MENHIR SOUND
- 100 MENHIR SOUND MINIMAL
- 104 MENHIR SOUND PRO

114 TEXTURE TEXTURES

- 116 ITALIAN FLOWERY GREY
- 118 ANGEL SPARKS
- 120 TRAVERTINO IVORY
- 122 ARTIC GREEN
- 124 BIANCO DI CARRARA
- 126 TRANI
- 127 VERDE CHALET
- 128 PIETRA DI LUSERNA
- 129 ARDESIA BLACK PILLAR
- 130 CIOTTOLONE BIANCO
- 131 OCEAN BLUE
- 132 LEGNO FOSSILE
- 133 VERDE ALPI
- GIALLO MORI
- NERO EBANO





# chi siamo about us

---

Da oltre dieci anni progettiamo esperienze di luce e suono che uniscono tecnologia, design e cultura del marmo, creando lampade e diffusori sonori pensati per chi desidera rendere gli spazi esterni personali e riconoscibili. Ogni oggetto nasce dalle nostre mani, dove l'esperienza illuminotecnica si intreccia con la lavorazione artigianale del marmo, dando vita a prodotti che portano carattere e personalità negli spazi quotidiani. Le nostre creazioni, presenti in progetti paesaggistici e architettonici in diverse parti del mondo, riflettono il nostro desiderio di creare qualcosa che non sia mai solo oggetto, ma esperienza, identità e bellezza.

---

*For over ten years, we have been crafting light and sound experiences that combine technology, design and marble culture, creating lamps and sound speakers designed for those who want to make outdoor spaces personal and recognisable. Each object is created by our own hands, where lighting expertise is intertwined with the craftsmanship of marble, giving life to products that bring character and personality to everyday spaces. Our creations, featured in landscaping and architectural projects around the world, reflect our desire to create something that is never just an object, but an experience, an identity, and an expression of beauty.*

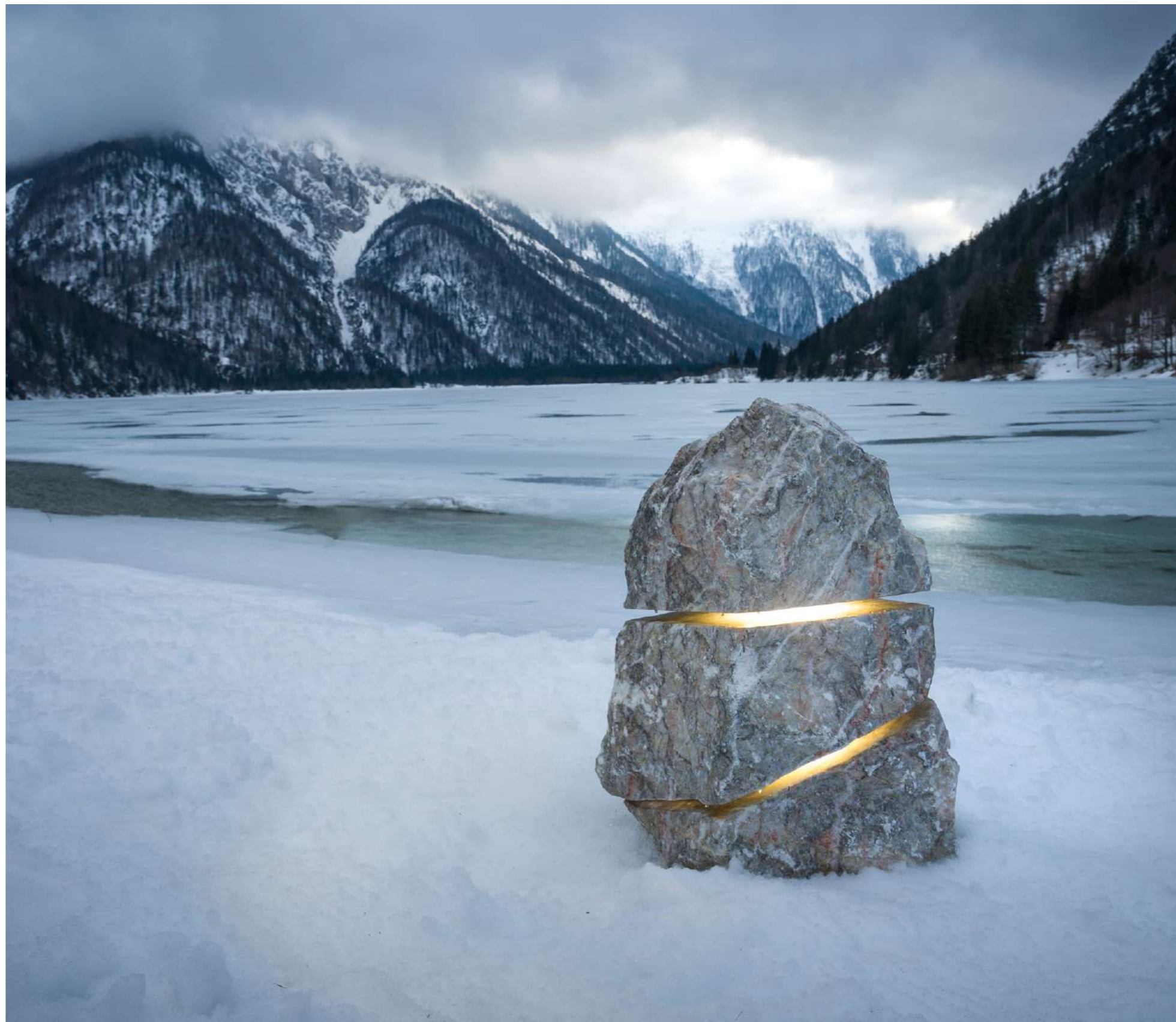



## il materiale the material



---

Crediamo fermamente che la pietra sia l'elemento materico che non può mancare in un progetto paesaggistico, perché capace di legare architettura e natura in un equilibrio duraturo. Per noi, il marmo ne è la massima espressione. Utilizziamo materiale di risulta proveniente dalle cave, una decisione responsabile che restituisce valore alla materia che lavoriamo con rispetto e attenzione, trasformandola in forme armoniose e funzionali, capaci di diffondere luce e suono con naturale eleganza. La pietra è il vestito perfetto e senza tempo di ogni nostra lampada e diffusore per esterni.

---

*We strongly believe that stone is an essential element in any landscape project, as it has the power to bring architecture and nature together in lasting harmony. For us, marble represents its highest expression. We use leftover materials sourced from quarries - a responsible choice that restores value to the matter we work with care and respect, transforming it into harmonious, functional forms capable of diffusing light and sound with natural elegance. Stone is the timeless, perfect attire of each of our outdoor lamps and sound speakers.*

# artigianalità craftmanship

Dall'ispirazione alla forma, ogni progetto nasce da una solida competenza illuminotecnica, che guida la progettazione e garantisce la qualità dei nostri prodotti. La conoscenza della luce si unisce alla maestria nella lavorazione del marmo, materiale che rappresenta la nostra firma estetica e l'equilibrio tra tecnica e design. Nel laboratorio in Friuli, progettisti e artigiani collaborano in ogni fase del processo: dalla selezione dei materiali al controllo delle componenti elettriche, fino all'assemblaggio finale. Ogni dettaglio è curato e verificato con precisione, perché solo l'abilità manuale può assicurare affidabilità, durata e coerenza di ogni creazione.

*From inspiration to design, every project stems from solid lighting expertise, which guides the process and guarantees the quality of our products. Knowledge of light is combined with expertise in marble processing, a material that represents our aesthetic signature and the balance between technology and design. In our workshop in Friuli, designers and artisans work together at every stage of the process: from the selection of materials to the testing of electric components and final assembly. Every detail is carefully checked and verified, because only manual skill can ensure the reliability, durability and consistency of each creation.*



fatto in Italia  
made in Italy



---

I nostri prodotti nascono in Italia, dove design e tradizione si incontrano per dare forma a oggetti raffinati e riconoscibili. Per noi un prodotto deve essere affidabile e duraturo, con un design senza tempo, capace di riflettere lo stile italiano: essenziale, elegante e inconfondibile. Il nostro Made in Italy non è solo un marchio di origine, ma un valore concreto che unisce innovazione e cultura del progetto, rendendo ogni creazione autentica e distintiva.

---

*Our products are created in Italy, where design and tradition come together to give shape to refined and recognisable objects. We firmly embrace the concept of a reliable and durable product with a timeless design that reflects Italian style: essential, elegant, and unmistakable. Our Made in Italy label is not just a mark of origin, but a tangible value that combines innovation and design culture, making each creation authentic and distinctive.*



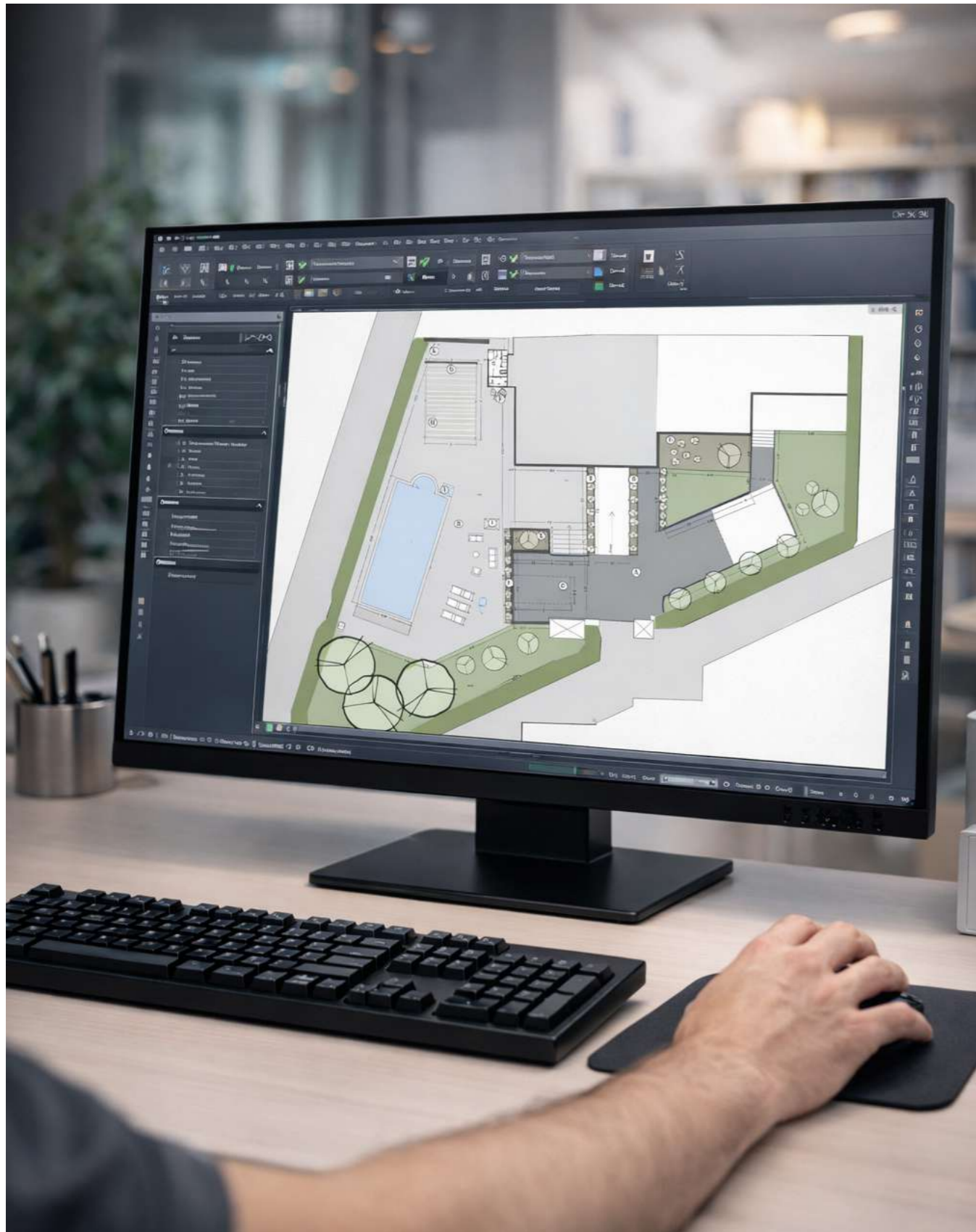

progettazione  
degli spazi: luce  
e suono in equilibrio  
space design:  
balanced light  
and sound



Ogni progetto viene studiato per valorizzare l'equilibrio tra luce e suono, creando scenari armoniosi ed efficaci che bilanciano estetica e performance. Il nostro servizio di progettazione si adatta a diverse esigenze, affiancando sia chi si avvicina per la prima volta ai nostri prodotti, sia professionisti e progettisti, con indicazioni su posizionamento e integrazione architettonica negli spazi outdoor.

Sono disponibili i file BIM/3D dei nostri prodotti, completi di curve fotometriche, per un'integrazione precisa nei software di progettazione e una rappresentazione fedele dell'impatto finale.

*Each project is designed to enhance the balance between light and sound, creating harmonious and striking scenarios that combine aesthetics and performance. Our design service adapts to different needs, supporting both those approaching our products for the first time and professionals and designers, with guidance on positioning and architectural integration in outdoor spaces.*

*BIM/3D files of our products are available, complete with photometric curves, for accurate integration into design software and a faithful representation of the final impact.*



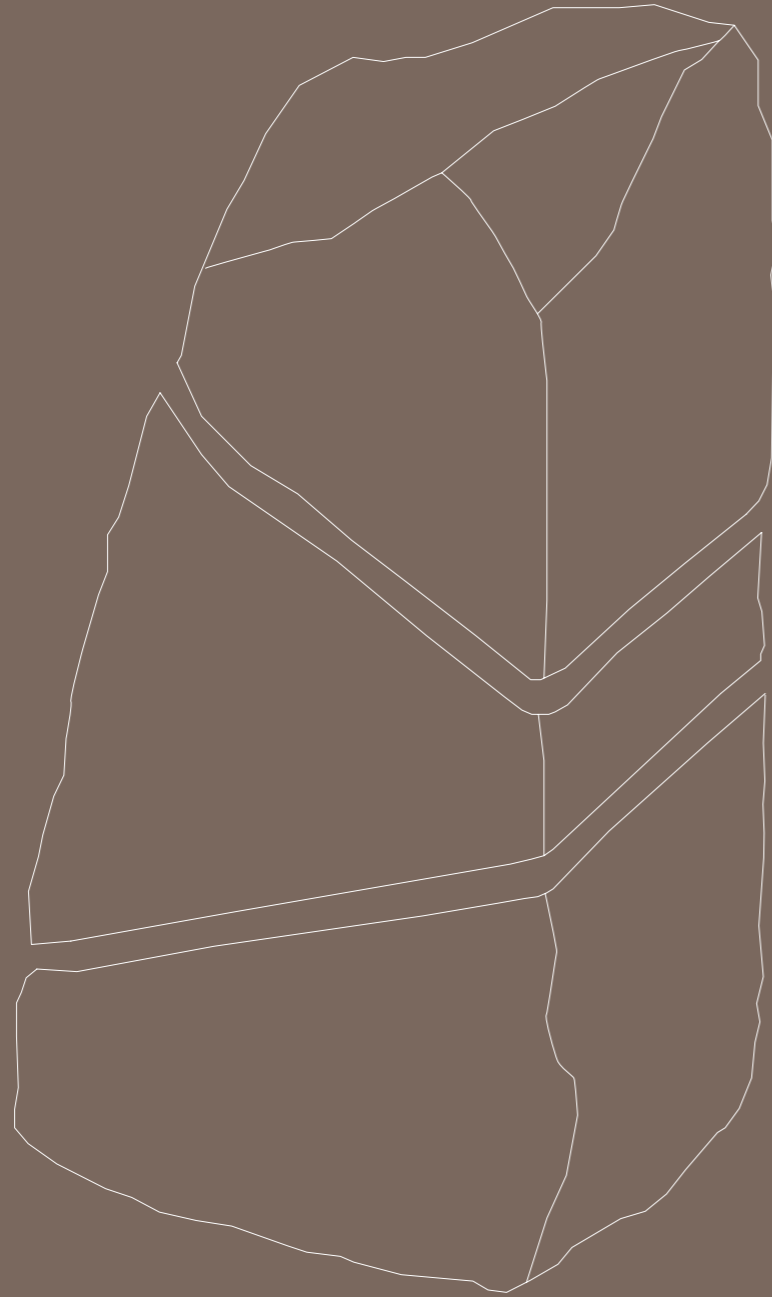

atmosfera	1
atmosphere	—
essenziale	2
essential	—
audio	3
audio	—



MENHIR DI LUCE



MENHIR MINIMAL



MENHIR POOL



RAY

Dall'incontro tra marmo e luce nascono le lampade della Collezione Atmosfera, pensate per chi desidera ambienti esterni eleganti e identitari. Il marmo, filo conduttore della collezione, avvolge ogni prodotto, dalle forme iconiche del Menhir alle linee più geometriche, conferendo continuità e personalità. Ogni oggetto è fatto a mano, numerato e personalizzabile, per creare scenari luminosi suggestivi e unici, adatti a integrarsi armoniosamente con diversi stili architettonici.

*The Atmosphere Collection lamps are born from the encounter between marble and light, designed for those who desire elegant and distinctive outdoor spaces. Marble, the common thread of the collection, envelops each product, from the iconic shapes of Menhir to the more geometric lines, giving consistency and personality. Each object is handmade, numbered and customisable, to create evocative and unique lighting scenarios that blend harmoniously with different architectural styles.*



# MENHIR DI LUCE

Menhir di Luce è la lampada iconica in marmo, disponibile in quattro varianti: Soft, Sidelong, Cross e Stonehenge, ognuna con un diverso effetto luminoso. Realizzata a mano in Italia e numerata singolarmente, può essere personalizzata nella scelta del marmo per adattarsi al progetto. La solidità della pietra si unisce a una luce diffusa e scenografica, ideale per valorizzare giardini, terrazze e spazi aperti con un segno distintivo.



*Menhir di Luce is the iconic marble lamp available in four versions: Soft, Sidelong, Cross and Stonehenge, each with a different lighting effect. Handcrafted in Italy and individually numbered, it can be customised with a choice of marble to suit the project. The solidity of the stone is combined with a diffused and decorative light, ideal for enhancing gardens, terraces and open spaces with a distinctive touch.*

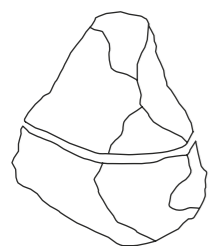

## SOFT

Indic. dim.	25x35x40 cm
Indic. weight	70 - 90 kg
Input	24V Dc
Total consumption	7W
Luminous flux	135 Lm
CCT	3.100K
IP rating	IP68

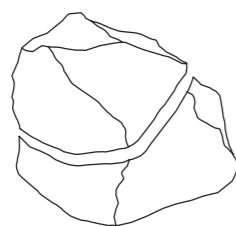

## SIDELONG

Indic. dim.	30x35x40 cm
Indic. weight	70 - 90 kg
Input	24V Dc
Total consumption	7W
Luminous flux	135 Lm
CCT	3.100K
IP rating	IP68

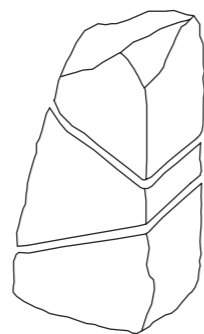

## CROSS

Indic. dim.	30x35x70 cm
Indic. weight	120 - 160 kg
Input	24V Dc
Total consumption	14W
Luminous flux	270 Lm
CCT	3.100K
IP rating	IP68

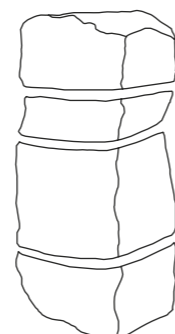

## STONEHENGE

Indic. dim.	30x30x75 cm
Indic. weight	140 - 180 kg
Input	24V Dc
Total consumption	21W
Luminous flux	470 Lm
CCT	3.100K
IP rating	IP68

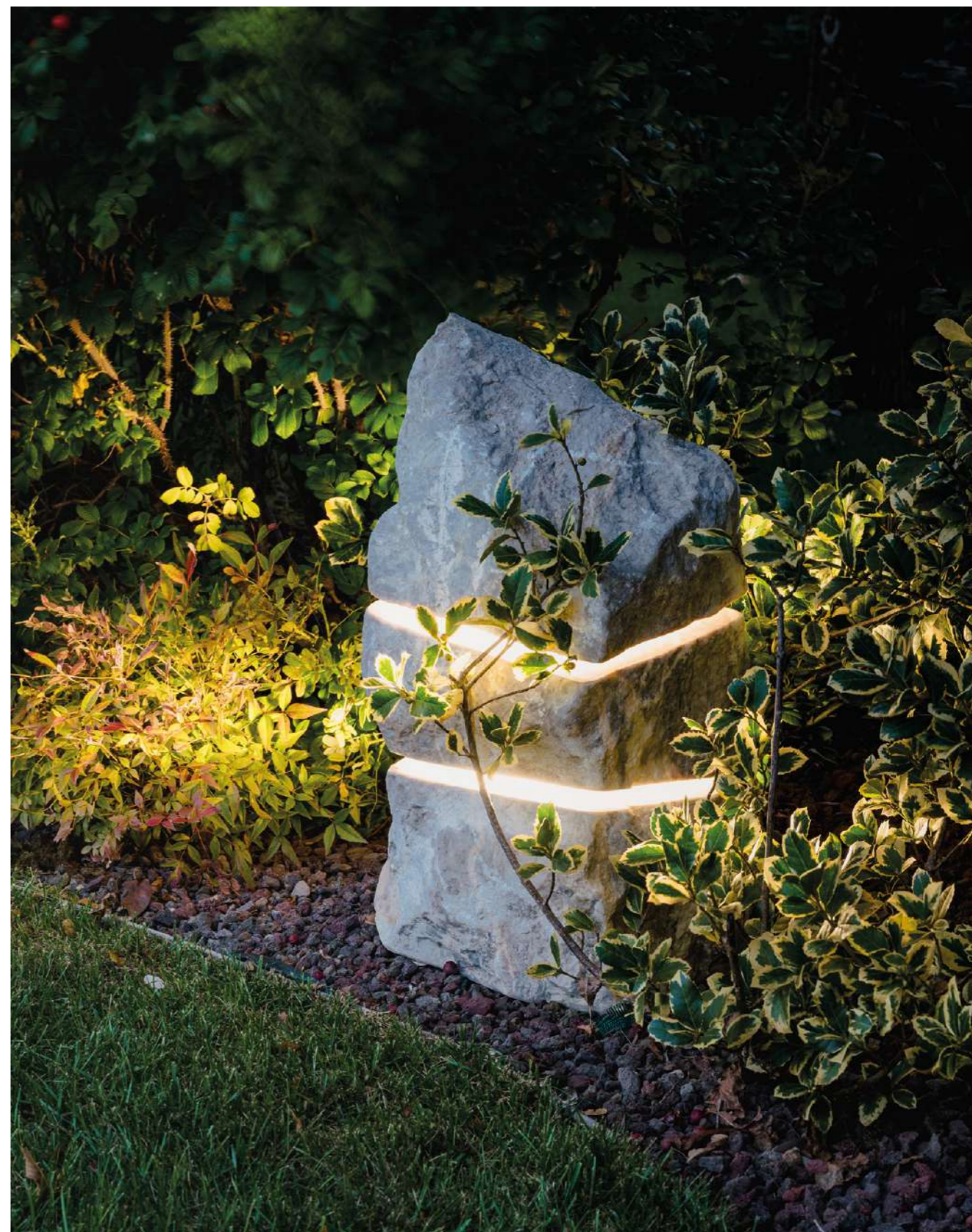

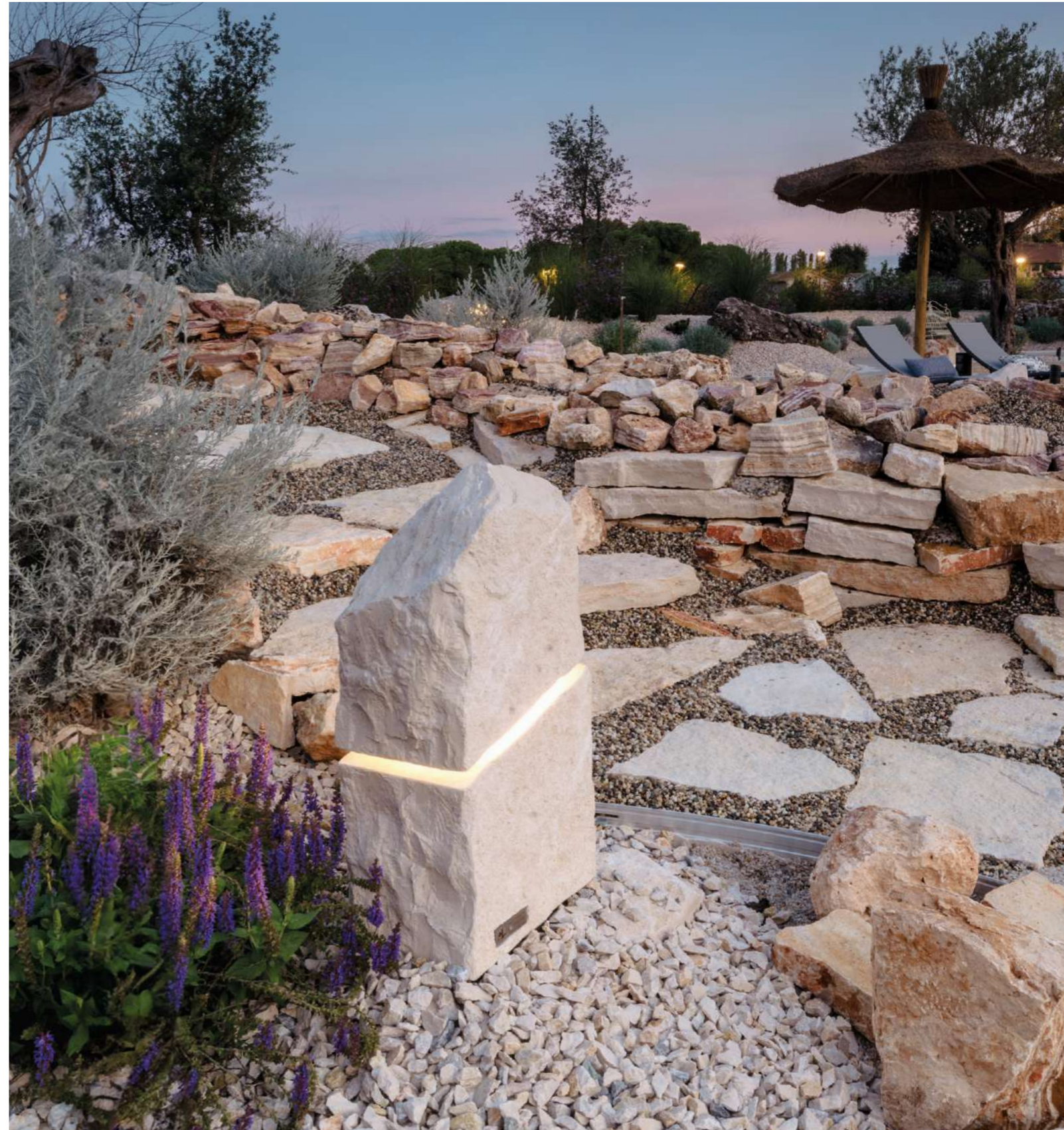

## CARATTERISTICHE | FEATURES



### Luce a tutto tondo All-round light

Elemento luminoso con struttura in alluminio e LED continuo a 360° per un'emissione uniforme e costante della luce.

*Lighting element with aluminium structure and 360° continuous LED designed to ensure uniform and constant light emission.*

### Progettato per durare Designed to last

Anello LED intercambiabile su tutti i Menhir, protetto da resinatura totale, per una sostituzione semplice e duratura.

*Interchangeable LED ring on all Menhir models, fully resin-sealed for simple and long-lasting replacement.*



### Identità Identity

Ogni Menhir nasce da un blocco di marmo selezionato e lavorato a mano; una placchetta in acciaio ne certifica unicità e numero di serie.

*Each Menhir is carved from a selected marble block and hand-finished; a stainless steel plate certifies its uniqueness and serial number.*

## TEXTURE | TEXTURES



Italian Flowery Grey



Trani



Angel Sparks\*



Artic Green\*



Ciottolone Bianco\*

\* Texture custom su richiesta | Custom textures on request



# MENHIR MINIMAL

Menhir Minimal è una lampada da esterno in marmo levigato, disponibile nelle forme squadrata (Minimal) o sferica (Sphera). Offre un design contemporaneo e raffinato, ideale per ambienti esterni moderni. La superficie liscia e levigata esalta la bellezza del materiale, mentre la luce diffusa crea atmosfere suggestive. Ogni pezzo è numerato singolarmente e la texture può essere personalizzata, selezionando il marmo che si adatta al progetto e allo stile desiderato.

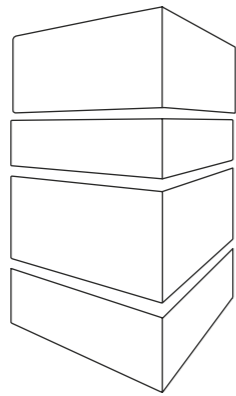

## MINIMAL

Indic. dimensions	30x30x60 cm
Indic. weight	130 - 160 kg
Input	24V Dc
Total consumption	21W
Luminous flux	470 Lm
CCT	3.100K
IP rating	IP68

*Menhir Minimal is an outdoor lamp in polished marble, available in square (Minimal) or spherical (Sphera) shapes. It offers a contemporary and refined design, ideal for modern outdoor environments. The smooth, polished surface enhances the beauty of the material, while the diffused light creates evocative atmospheres. Each piece is individually numbered and the texture can be customised by selecting the marble that best suits the project and the desired style.*

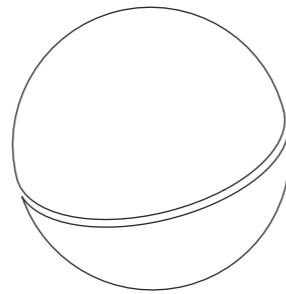

## SPHERA

Indic. dimensions	Ø 35 cm
Indic. weight	50 - 70 kg
Input	24V Dc
Total consumption	7W
Luminous flux	135 Lm
CCT	3.100K
IP rating	IP68

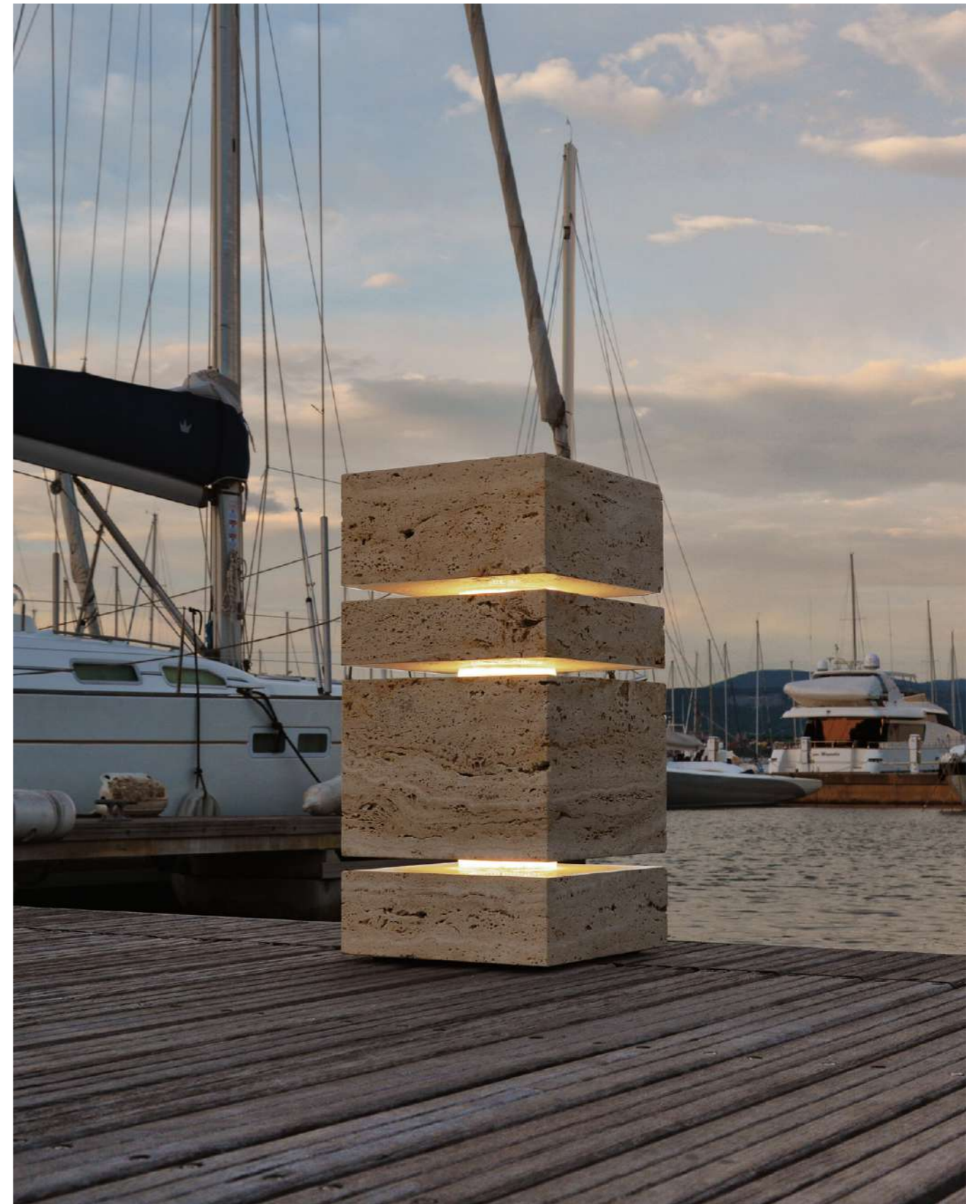



## CARATTERISTICHE | FEATURES

### Luce a tutto tondo All-round light

Diffonde luce a 360° con temperatura colore di 3.100K, chiara ed elegante, ideale per ambienti esterni moderni.

*It diffuses light at 360° with a color temperature of 3.100K, clear and refined, ideal for modern outdoor settings.*



### Levigata a mano Hand-polished

Ogni lato del blocco è levigato e rifinito a mano per una superficie liscia che valorizza venature e colori naturali del marmo.

*Each side of the lamp is hand-polished and finished to a smooth surface that enhances the marble's natural veins and colors.*

### Luce e materia Light and Materials

La luce della lampada interagisce con il marmo che ne modifica la percezione cromatica, creando sfumature diverse a seconda della texture scelta.

*The lamp's light interacts with the marble, altering its perceived color and creating different shades depending on the chosen texture.*



## TEXTURE | TEXTURES



Italian Flowery Grey



Travertino Ivory



Verde Chalet



Bianco Carrara



# MENHIR POOL

Menhir Pool è la lampada in pietra naturale progettata per piscine, laghetti e fontane. Nella versione Twice, integra due tagli di luce: uno sotto il livello dell'acqua e uno sopra, per valorizzare sia gli spazi sommersi che quelli esterni.

È realizzata con componenti resistenti e sicure, pensate per durare in ambienti complessi e a contatto diretto con acque salate o clorate. Ogni pezzo è fatto a mano, numerato e personalizzabile nella scelta della pietra, per adattarsi perfettamente al progetto.



*Menhir Pool is a natural stone lamp designed for eco-pools, lagoons and fountains. The Twice version features two light sources: one below the water level and one above, to enhance both underwater and above-water areas. It is made with durable, safe components designed to withstand harsh environments and direct contact with salt or chlorinated water. Each piece is handmade, numbered and customisable in terms of stone choice, to fit perfectly with the project.*

## TWICE

Indic. dimensions	35x30x45 cm
Indic. weight	120 - 160 kg
Input	24V Dc
Total consumption	14W
Luminous flux	270 Lm
CCT	3.100K
IP rating	IP68

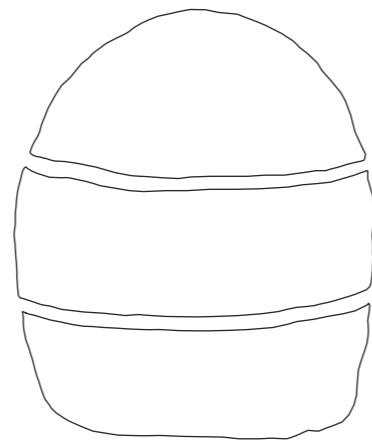

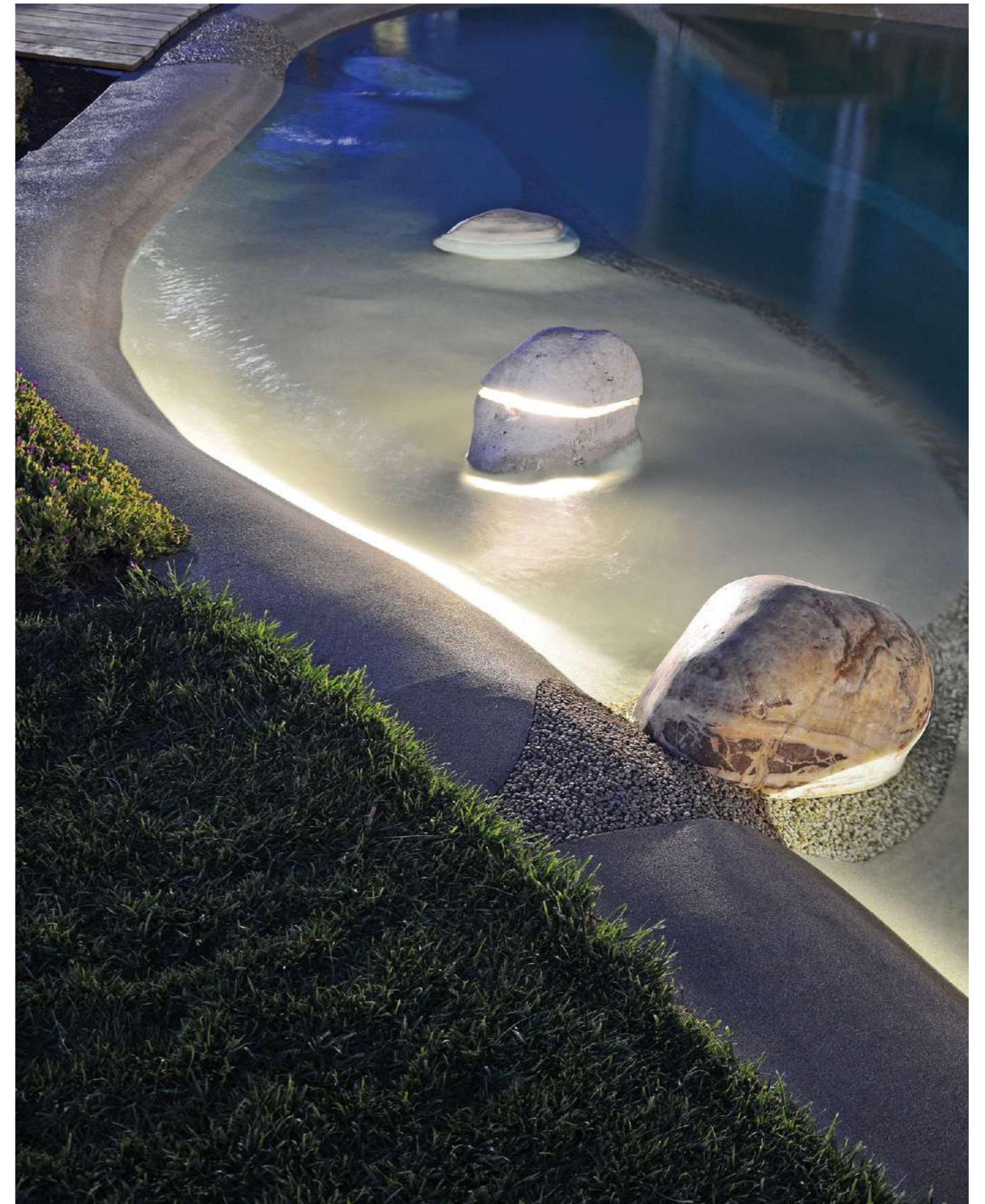

## CARATTERISTICHE | FEATURES

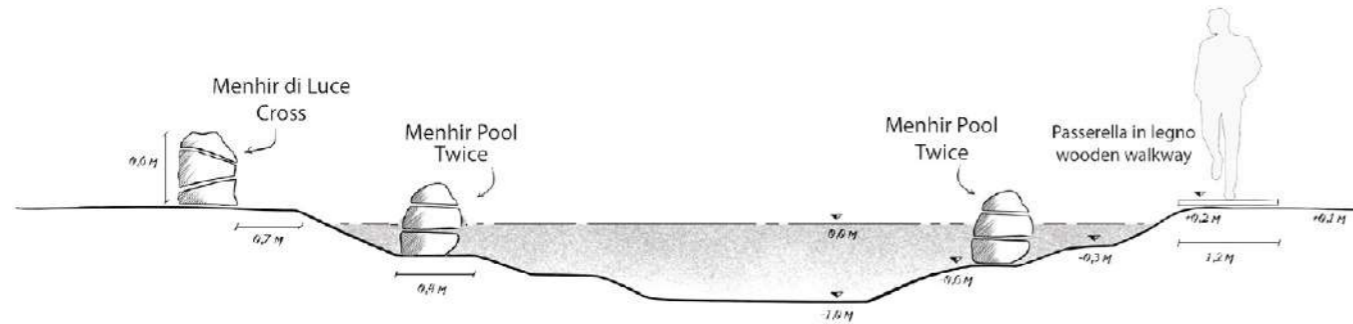

### Sotto e sopra il livello dell'acqua Above and below the water

L'emissione luminosa sotto e sopra il livello dell'acqua diffonde luce a 360° che viene amplificata dalle proprietà di trasparenza e riflessione dell'acqua stessa.

*The light emitted above and below the water's surface spreads in all directions, amplifying the effect through the water's transparency and reflective properties.*

### Sicura balneazione Safe bathing

Realizzata in granito o basalto, resistenti ad acqua salata e clorata, si presenta con forme arrotondate senza spigoli per garantire sicurezza in balneazione.

*Made of granite or basalt, resistant to salt and chlorinated water, it features rounded shapes with no sharp edges to ensure safe bathing.*

### Impermeabilità totale Completely waterproof

L'anello LED resinato con cavo continuo da 5 metri assicura un'installazione sicura senza giunzioni in area balneabile.

*The resin-sealed LED ring with a continuous 5-meter cable ensure safe installation without joints in swimming areas.*



## TEXTURE | TEXTURES



Ocean Blue



# RAY

Ray è una lampada compatta in marmo dalle piccole dimensioni, ideale per illuminare aiuole, fioriere e piccoli angoli verdi. Il design minimale si unisce al vetro extrachiaro satinato, che diffonde la luce in modo uniforme e delicato. Lavorata interamente a mano e disponibile in quattro finiture di marmo dalle nuance naturali, Ray si integra con discrezione in qualsiasi progetto outdoor, creando punti luce eleganti e funzionali.



*Ray is a compact marble lamp with small dimensions, ideal for lighting flower beds, planters and small green corners. The minimalist design is combined with extraclear satin-finished glass, which diffuses light evenly and delicately. Entirely handmade and available in four marble finishes with natural shades, Ray discreetly blends into any outdoor project, creating elegant and functional points of light.*

Indic. dimensions	15x12x9 cm
Indic. weight	1,5 - 2 kg
Input	24V Dc
Total consumption	2W
Luminous flux	75 Lm
CCT	3.000K
IP rating	IP68

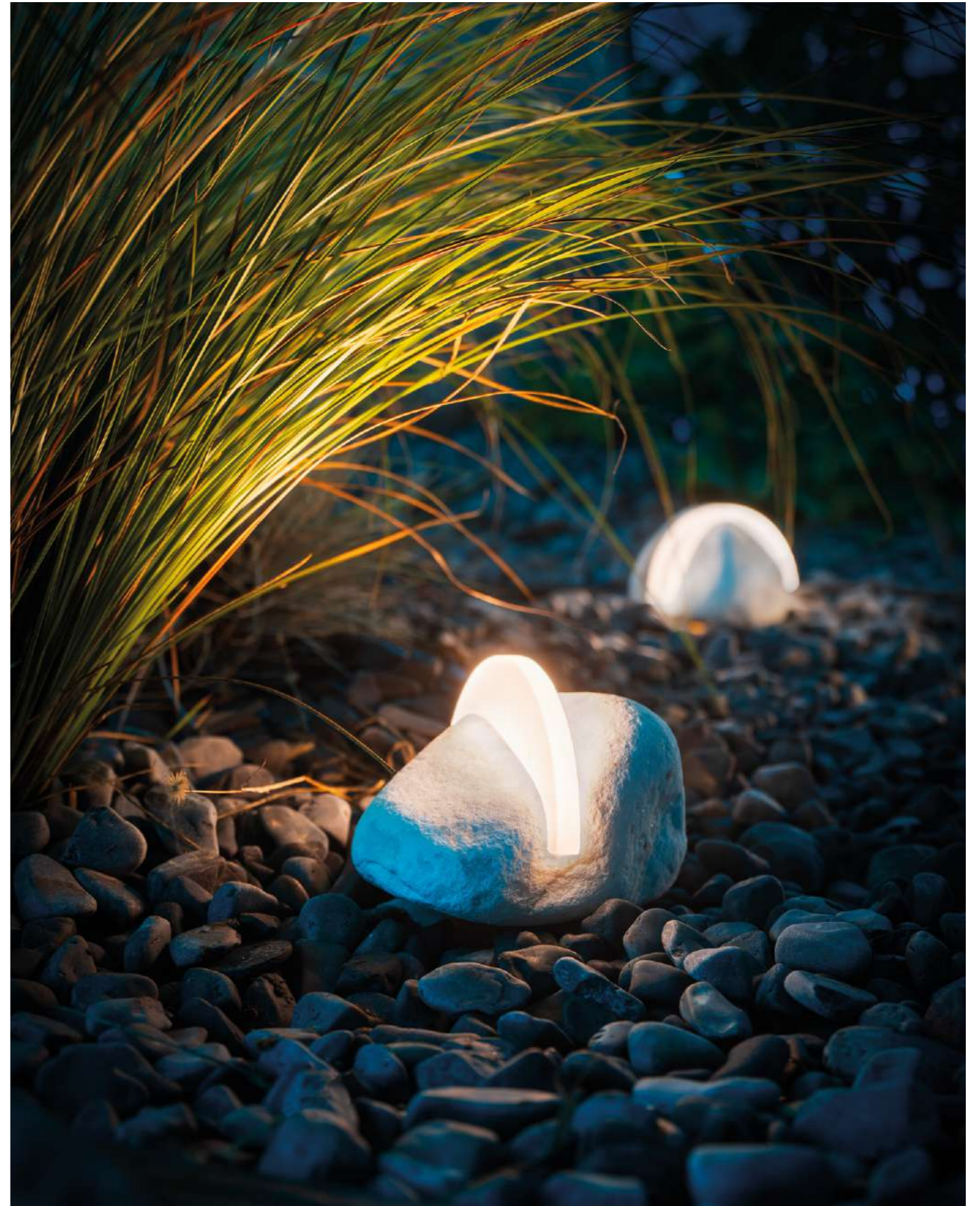
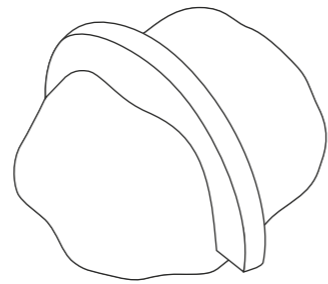

RAY



## CARATTERISTICHE | FEATURES

### Integrazione totale Total integrated design

Si integra in aiuole e contesti esterni, su letto di ciottoli ton sur ton, illuminando senza alterare il paesaggio.

*It blends into flowerbeds and outdoor settings, placed on a bed of color-matching pebbles, illuminating without altering the landscape.*



### Cuore LED LED heart

Modulo in alluminio progettato per una sostituzione rapida e semplice della sorgente luminosa.

*Aluminium module designed for quick and easy replacement of the light source.*



### Diffusore in vetro Glass diffuser

La mezzaluna in vetro extrachiaro satinato diffonde una luce morbida e non abbagliante.

*The extraclear satin-finished glass half-moon diffuses a soft, glare-free light.*

## TEXTURE | TEXTURES



Bianco Carrara



Nero Ebano



Verde Alpi



Giallo Mori

atmosfera 1  
atmosphere —

essenziale 2  
essential —

audio 3  
audio —





STAKE

La Collezione Essenziale illumina vialetti, aiuole e passaggi con lampade compatte e leggere, pensate per guidare la luce con precisione. Nel nostro laboratorio ogni lampada prende forma con componenti illuminotecniche progettate da noi, pensate per integrarsi perfettamente con la pietra e garantire prestazioni affidabili nel tempo. Il marmo, elemento distintivo della collezione e nostro DNA, conferisce carattere anche alle forme più essenziali. Così la Collezione Essenziale unisce funzionalità ed eleganza, dando valore a ogni angolo del giardino.



FOCUS

*The Essential Collection illuminates paths, flower beds and walkways with compact, lightweight lamps designed to guide light with precision. In our workshop, each lamp is made of lighting components designed by us, created to blend perfectly with the stone and guarantee reliable performance over time. Marble, a distinctive feature of the collection and part of our DNA, gives character to even the most essential shapes. The Essential Collection combines functionality and elegance, adding value to every corner of the garden.*



SOL



FLOR



# STAKE

Stake è un paletto luminoso dal design essenziale, progettato per illuminare vialetti e camminamenti. La base in acciaio inox con quattro picchetti garantisce stabilità e un'installazione semplice e sicura, mentre il corpo in marmo o pietra naturale veste la lampada con linee pulite e discrete. La sorgente LED di soli 4 mm è custodita in un profilo verticale in alluminio satinato, un dettaglio tecnico che valorizza la luce senza appesantire il design. Questa combinazione di elementi rende Stake un prodotto unico nel panorama dei paletti da esterno.



*Stake is a bollard light with a minimalist design, designed to illuminate paths and walkways. The stainless steel base with four pegs ensures stability and simple, secure installation, while the marble or natural stone body gives the lamp clean, discreet lines. The LED light source, measuring just 4 mm, is enclosed in a vertical satin-finish aluminium profile, a technical detail that enhances the light without weighing down the design. This combination of elements makes Stake a unique product in the outdoor bollard scenario.*

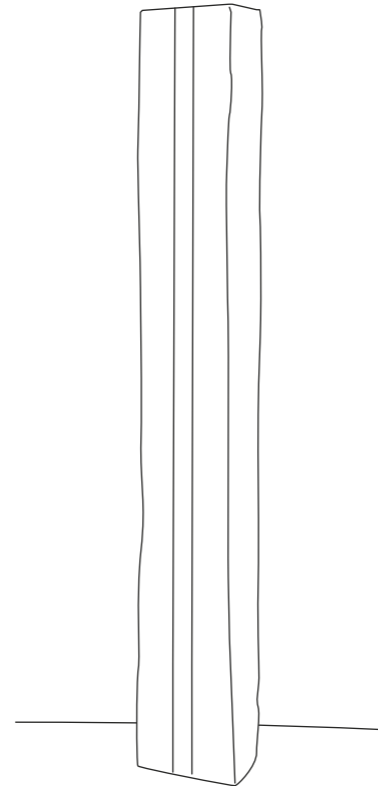

Indic. dimensions	8x10x60 cm
Indic. weight	10 - 12 kg
Input	24V Dc
Total consumption	6W
Luminous flux	110 Lm
CCT	2.700K
IP rating	IP68





## CARATTERISTICHE | FEATURES

### Luce bidirezionale Bi-directional light

Può integrare due barre LED opposte per un'illuminazione bidirezionale, su progetto.

*It can integrate two opposite LED bars for bidirectional lighting, on request.*

### Alluminio VS total black Aluminium vs total black

La barra centrale può essere rifinita in alluminio argento o nero anodizzato per un'estetica più decisa e moderna.

*The central bar can be finished in silver aluminium or black anodised for a more striking and modern aesthetic.*



### Fissaggio rapido Fast fixing

Fissaggio a terra con piastra in acciaio inox e quattro picchetti, per un facile riposizionamento in caso di urti.

*Ground fixing with a stainless steel plate and four pegs, allowing easy repositioning in case of impact.*

## TEXTURE | TEXTURES



Ardesia Black Pillar



Trani



Angel Sparks\*



Verde Chalet\*



Italian Flowery Grey\*



Luserna\*



Bianco Carrara\*

\* Texture custom su richiesta | Custom textures on request



# FOCUS

Focus è un faretto da esterno dal look minimalista, progettato per illuminare piante, arbusti e dettagli architettonici. Il cilindro in marmo ospita un LED da 4,5W, che garantisce un fascio di luce precisa con un angolo di 30° o 60°. Si fissa al terreno tramite un picchetto in acciaio inox, lo stelo della lampada è flessibile, disponibile in due altezze (30 cm e 50 cm) e rivestito in corda nautica resistente agli agenti esterni, emergendo dal terreno e valorizzandone la pietra.



*Focus is an outdoor spotlight with a minimalist look, designed to illuminate plants, shrubs and architectural details. The marble cylinder houses a 4,5W LED, providing precise lighting with a 30° or 60° beam angle. It is fixed to the ground with a stainless steel spike, while the bendable stem, available in two heights (30 cm and 50 cm) and covered in nautical rope resistant to external agents, makes it stand out from the ground, enhancing the stone.*

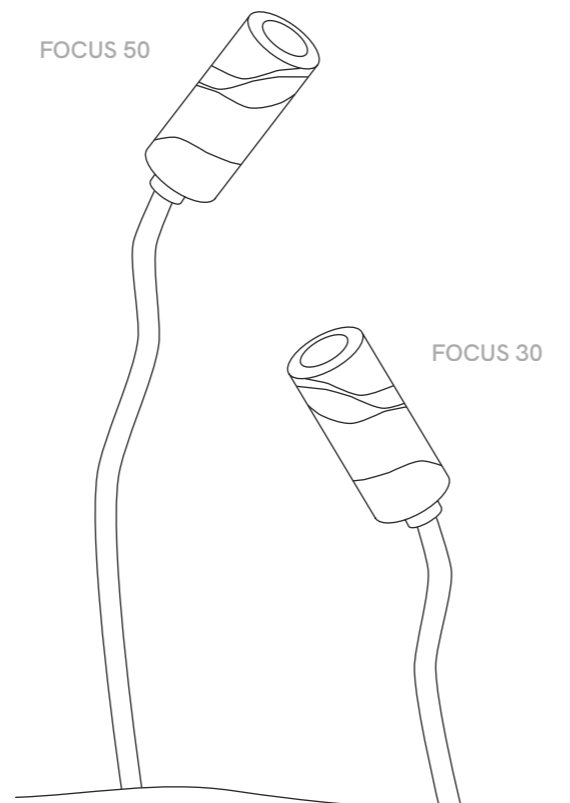

Indic. dimensions	Ø 4,0 cm   h: 30 cm   50 cm
Indic. weight	570 - 650 gr
Input	24V Dc
Total consumption	4,5W
Luminous flux	480 Lm
CCT	3.000K
IP rating	IP68





## CARATTERISTICHE | FEATURES

### Fusto orientabile Adjustable stem

Sistema Flex & Stay per orientare manualmente il fusto e mantenerne la posizione, rivestito in corda nautica resistente agli agenti atmosferici.

*Flex & Stay system for manually adjusting the stem and keeping it in position, wrapped in weather-resistant nautical rope.*



### LED di ultima generazione Latest generation LED

LED disponibile con lente da 30° o 60° per due diversi effetti del fascio luminoso. Resinatura per isolamento totale dall'acqua.

*LED available with 30° or 60° lens for two different beam effects. Resin coating for complete water protection.*



### Fissaggio rapido Fast fixing

Spike è il picchetto in acciaio inox da 25 cm per il fissaggio a terra della lampada, compatibile con i modelli Focus, Sol e Flor.

*Spike is a 25 cm stainless steel stake used to fix the lamp to the ground, and is compatible with the Focus, Sol and Flor models.*

## TEXTURE | TEXTURES



Italian Flowery Grey



Travertino Ivory

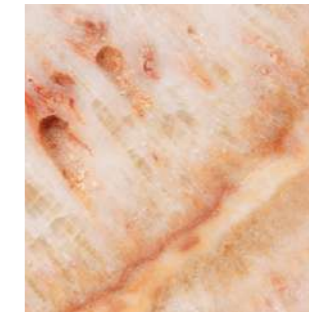

Angel Sparks\*



Artic Green\*

## FUSTO | STEM



Black



Forest Green



Greige

\* Texture custom su richiesta | Custom textures on request



# SOL

Sol è una lampada da esterno, con testa tonda in marmo, cuore LED e corpo in acciaio nero: un'anatomia studiata per esaltare l'equilibrio tra forme, proporzioni e materiali. La luce, progettata per essere tecnica e orientata verso il basso, evita l'abbagliamento e genera una nuvola luminosa potente e controllata, capace di valorizzare ogni spazio esterno.

*Sol is an outdoor lamp, featuring a round marble head, LED core and black steel body: an anatomy conceived to enhance the balance between shapes, proportions and materials. The light, designed to be technical and downward-facing, avoids glare and generates a powerful and controlled luminous cloud, capable of elevating any outdoor space.*



Indic. dimensions	Ø 9,0 cm   h: 70 cm   100 cm   130 cm
Indic. weight	680 - 740 - 870 gr
Input	24V Dc
Total consumption	2,7W
Luminous flux	370 Lm
CCT	3.000K
IP rating	IP68

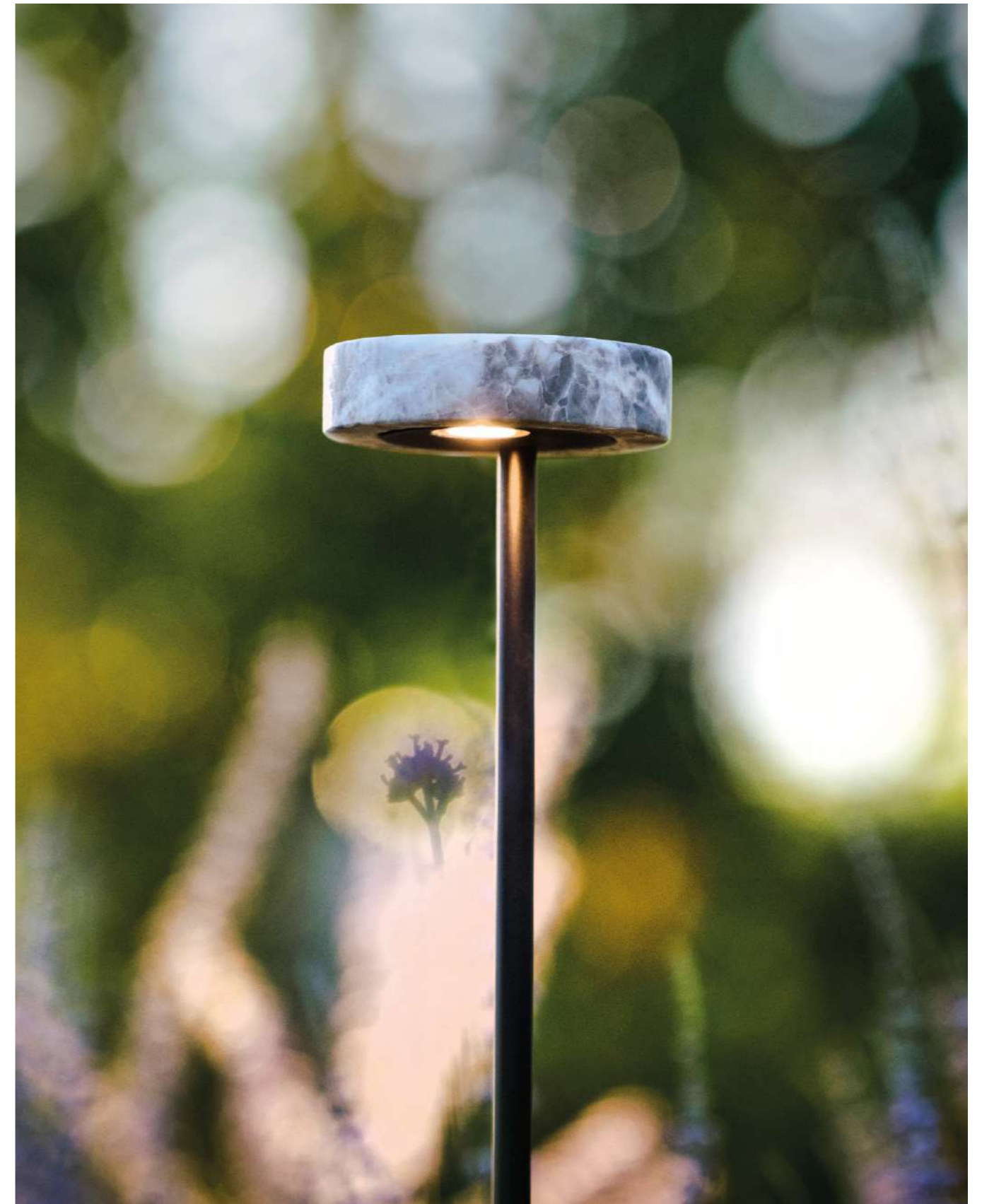
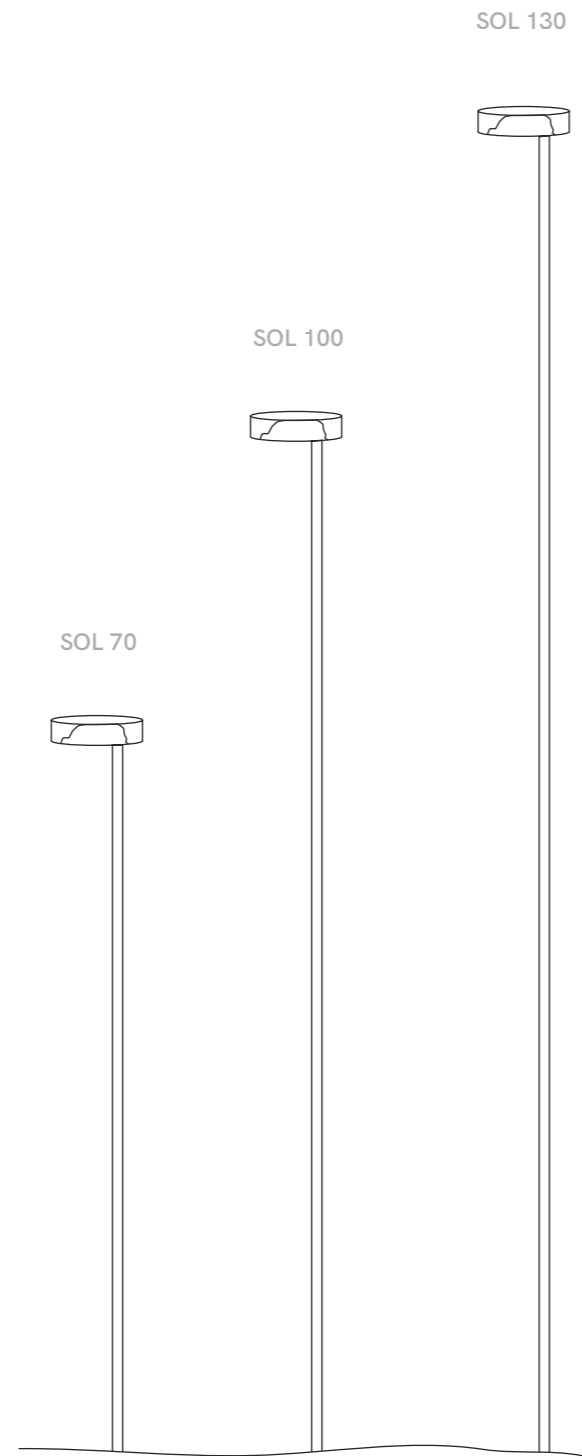

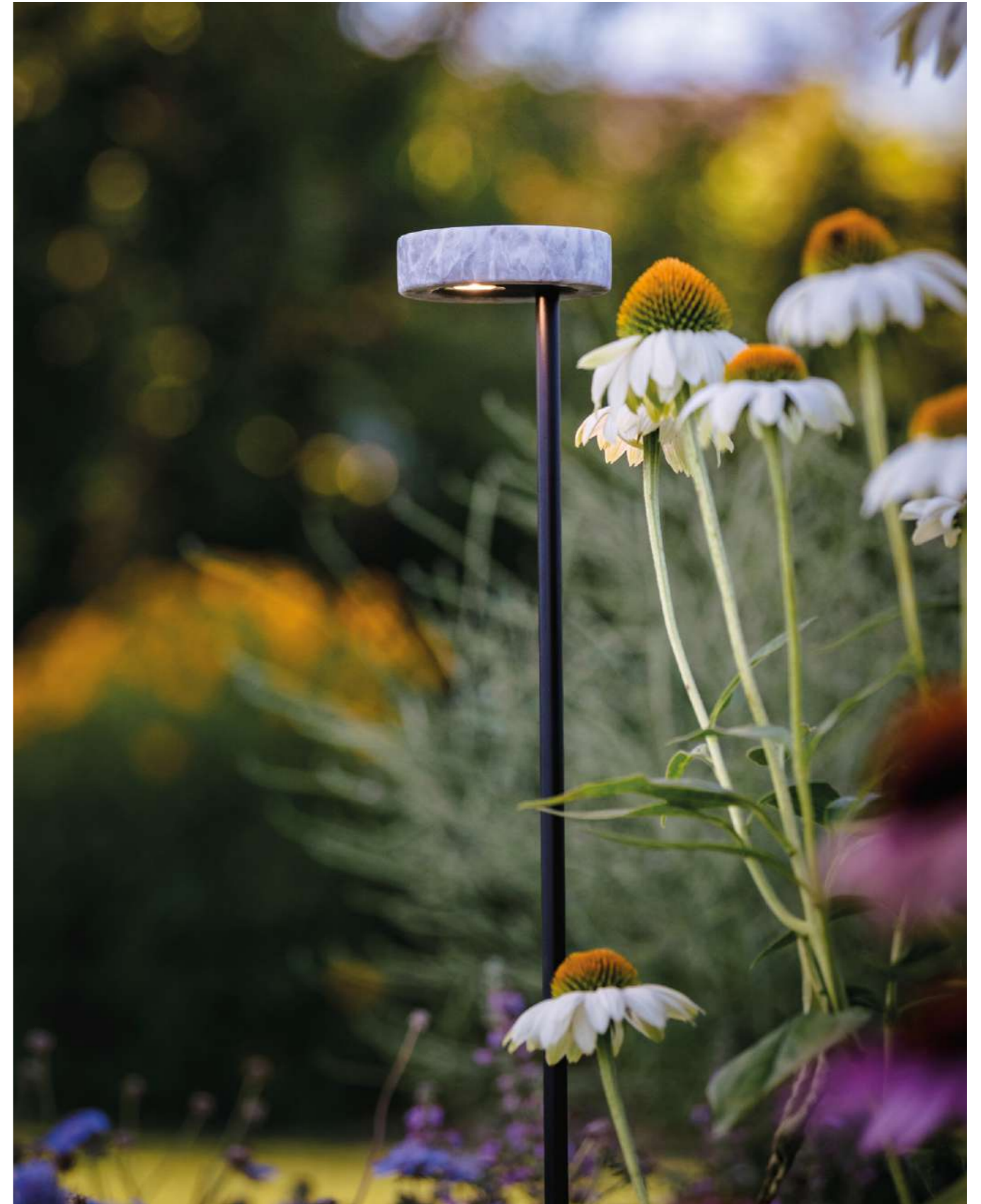

## CARATTERISTICHE | FEATURES

Luce indiretta  
Glare-free light

Emissione LED verso il basso, con apertura di 120°, per evitare abbagliamento. Resinatura e IP68 garantiscono isolamento dall'acqua e assenza di condensa.

*Downward LED light output, with a 120° beam angle, to prevent glare. The resin coating and IP68 rating ensure water resistance and prevent condensation.*

Nero opaco  
Matte black

Fusto in acciaio inox verniciato nero opaco RAL 9005, per ridurre i riflessi e integrarsi nella vegetazione nelle ore notturne.

*Stainless steel body finished in RAL 9005 matte black reduces reflections and blends into surrounding vegetation at night.*

Fissaggio rapido  
Fast fixing

Spike è il picchetto in acciaio inox da 25 cm per il fissaggio a terra della lampada, compatibile con i modelli Sol, Flor e Focus.

*Spike is a 25 cm stainless steel stake used to fix the lamp to the ground, and is compatible with the Sol, Flor and Focus models.*

## TEXTURE | TEXTURES



Italian Flowery Grey



Travertino Ivory



Angel Sparks\*



Artic Green\*

\* Texture custom su richiesta | Custom textures on request



# FLOR

Flor è uno stelo di luce che si confonde tra i fiori e prende vita al calar del sole. Il fusto in rame flessibile, rivestito da una trama tessile per esterni, è pensato per essere modellato liberamente, rendendo la lampada malleabile come un elemento naturale del giardino. In cima, un cilindro di marmo custodisce un piccolo LED che illumina con precisione aiuole e spazi verdi. La natura flessibile della lampada Flor permette di orientare la luce in modi sempre nuovi, adattandola al mutare della vegetazione, trasformando l'illuminazione in un gesto creativo.



*Flor is a stem of light that blends in with the flowers and comes to life at sunset. The flexible copper trunk, covered with an outdoor textile fabric, is designed to be freely shaped, making the lamp as malleable as a natural element of the garden. At the top, a marble cylinder houses a small LED that precisely illuminates flower beds and green spaces. The pliability of the lamp allows to direct the light in ever-changing ways, adapting to the vegetation and transforming lighting into a creative gesture.*

Indic. dimensions	Ø 2,8 cm   h: 100 cm   150 cm
Indic. weight	300 - 380 gr
Input	24V Dc
Total consumption	1,35W
Luminous flux	166 Lm
CCT	3.000K
IP rating	IP68

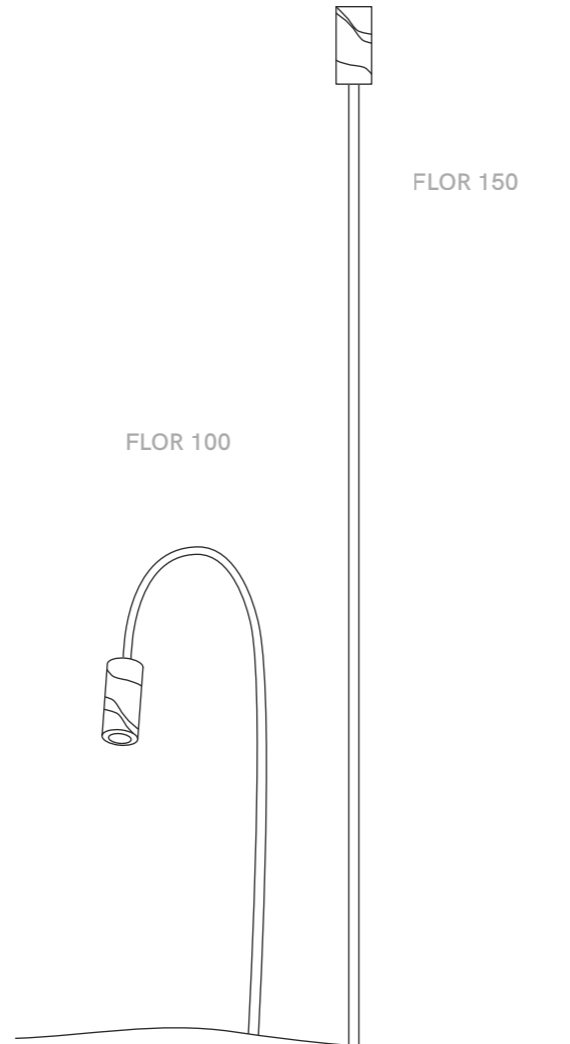



## CARATTERISTICHE | FEATURES

### Luce direzionabile Adjustable light

Fusto in rame rivestito in corda nautica, flessibile verso il basso per una luce morbida su piante e fioriture.

*A copper stem covered in nautical rope, which bends downwards to cast a soft light on plants and flowers.*



### Fissaggio rapido Fast fixing

Spike è il picchetto in acciaio inox da 25 cm per il fissaggio a terra della lampada, compatibile con i modelli Flor, Sol e Focus.

*Spike is a 25 cm stainless steel used to fix the lamp to the ground, and is compatible with the Flor, Focus and Sol models.*



### Compatto e leggero Compact and lightweight design

Compatto ma potente, il cilindro in alluminio anodizzato nero ospita un LED di ultima generazione a basso consumo e alta efficienza luminosa.

*Compact yet powerful: black anodized aluminium cylinder with a latest-generation, energy-efficient LED.*

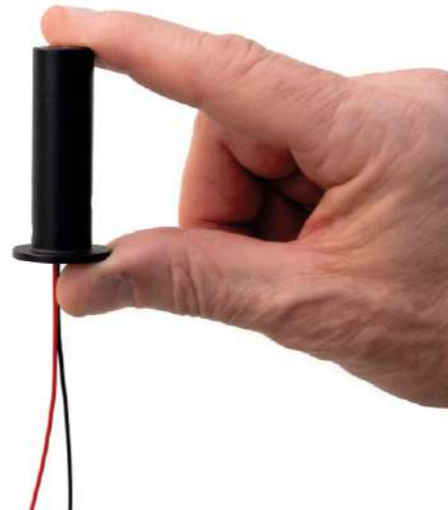

## TEXTURE | TEXTURES



Italian Flowery Grey



Travertino Ivory



Angel Sparks\*



Artic Green\*

## FUSTO | STEM



Black



Forest Green



Greige

\* Texture custom su richiesta | Custom textures on request

essenziale 1  
essential —

atmosfera 2  
atmosphere —

audio 3  
audio —

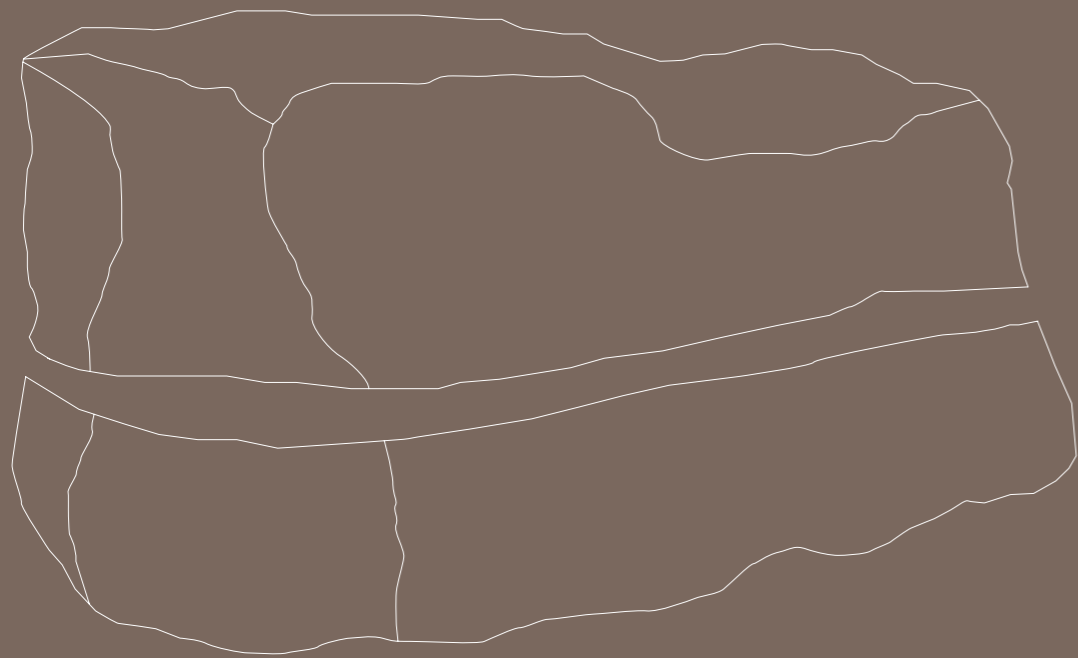



MENHIR SOUND



MENHIR SOUND MINIMAL



MENHIR SOUND PRO

I diffusori sonori per esterno della Collezione Audio offrono soluzioni di luce e suono pensate per valorizzare giardini, terrazze e spazi aperti, creando ambienti esclusivi e raffinati. Ogni Menhir, icona della nostra artigianalità, integra tecnologia luminosa e audio in un'unica forma, garantendo diffusione sonora su misura senza altoparlanti a vista o dettagli tecnici che interrompano l'armonia. Solo design e atmosfera, per un'esperienza acustica immersiva in ogni angolo del giardino. Con Menhir Sound, la musica diventa parte del paesaggio.

*The outdoor speakers from the Audio Collection are designed to enhance gardens, terraces and open spaces with lighting and sound solutions creating exclusive and refined environments. Each Menhir, an icon of our craftsmanship, integrates lighting and audio technology into a single form, ensuring tailor-made sound diffusion without visible speakers or technical details that interrupt the harmony. Nothing but design and atmosphere, for an immersive acoustic experience in every corner of the garden. With Menhir Sound, music becomes part of the landscape.*



# MENHIR SOUND

Menhir Sound è un diffusore sonoro per esterni unico al mondo, la cui forma iconica scolpita a mano in marmo non ha eguali nel panorama dei prodotti audio outdoor. Il sistema audio da 30W diffonde musica con precisione e senza altoparlanti a vista. Compatibile con app e sistemi domotici, trasforma giardini e terrazze in ambienti multisensoriali, dove luce e suono convivono armoniosamente, creando un'esperienza esclusiva e riconoscibile. Ogni esemplare è contrassegnato da un numero di serie, testimonianza del lavoro artigianale e della cura dedicata a ciascun Menhir.

Per utilizzare i diffusori audio è necessario disporre di un amplificatore e/o un ricevitore a seconda del modello.



Indic. dimensions	60x35x40 cm
Indic. weight	150 - 200 kg
Input	24V Dc
Total consumption	14W
Luminous flux	210 Lm
CCT	3.100K
IP rating	IP67
Audio technical data	30W Rms@8Ω
Audio frequency range	90 - 20.000 Hz

*Menhir Sound is a unique outdoor speaker, whose iconic hand-sculpted marble shape is unmatched in the world of outdoor audio products. The 30W audio system plays music with precision and without visible speakers. Compatible with apps and home automation systems, it transforms gardens and terraces into multisensory environments, where light and sound coexist harmoniously, resulting in an exclusive and recognisable experience. Each piece is marked with a serial number, reflecting the craftsmanship and care dedicated to each Menhir.*

*To operate the audio speakers, you will need an amplifier and/or receiver, depending on the model.*

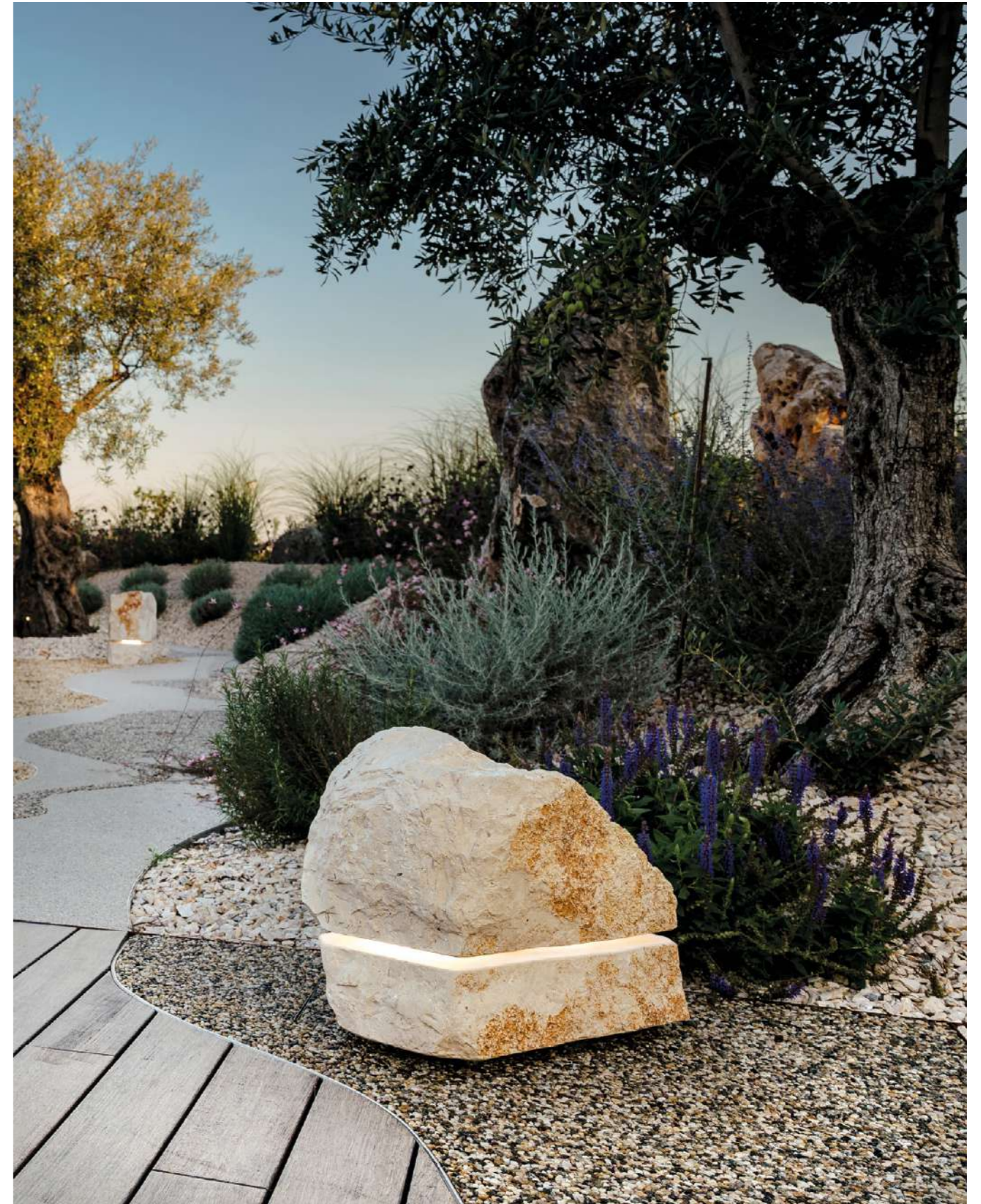
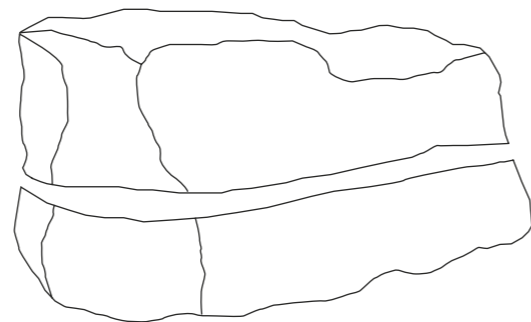





# MENHIR SOUND MINIMAL

Menhir Sound Minimal è un diffusore sonoro per esterni con sistema audio da 30W, che diffonde musica con precisione e senza altoparlanti a vista. La forma geometrica e lineare, levigata a mano in marmo, valorizza il design moderno degli spazi esterni, integrandosi con discrezione in giardini, terrazze e contesti architettonici contemporanei. Compatibile con app e sistemi domotici, offre possibilità di personalizzazione nella scelta del marmo. Ogni esemplare, realizzato e configurato per chi lo sceglie, è contrassegnato da un numero di serie.

Per utilizzare i diffusori audio è necessario disporre di un amplificatore e/o un ricevitore a seconda del modello.

*Menhir Sound Minimal is an outdoor sound speaker with a 30W audio system that plays music with precision and with no visible speakers. Its geometric, linear shape, hand-polished in marble, enhances the modern design of outdoor spaces, discreetly integrating into gardens, terraces and contemporary architectural contexts. Compatible with apps and home automation systems, it offers customisation options in the choice of marble. Each piece is marked with a serial number, designed, made and set up for those who choose it.*

*To operate the audio speakers, you will need an amplifier and/or receiver, depending on the model.*



Indic. dimensions	55x30x35 cm
Indic. weight	120 - 150 kg
Input	24V Dc
Total consumption	14W
Luminous flux	210 Lm
CCT	3.100K
IP rating	IP67
Audio technical data	30W Rms@8Ω
Audio frequency range	90 - 20.000 Hz

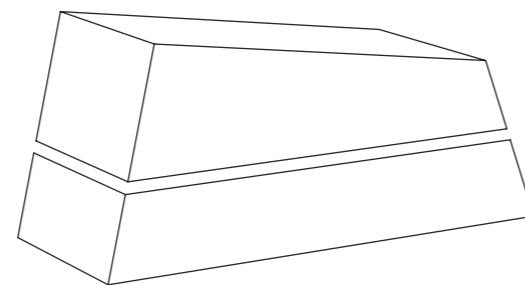



# MENHIR SOUND PRO

Menhir Sound Pro è il diffusore per esterni potente e vibrante, con sistema audio da 220W e woofer integrato per enfatizzare i toni bassi, capace di riempire giardini, terrazze e spazi aperti con un suono intenso e controllato, senza altoparlanti a vista. La forma iconica, scolpita a mano in marmo, unisce design, tecnologia audio e illuminazione, conferendo carattere e prestigio allo spazio esterno. Compatibile con app e sistemi domotici, offre possibilità di personalizzazione nella scelta del marmo. Ogni esemplare è unico, potente e riconoscibile.

Per utilizzare i diffusori audio è necessario disporre di un amplificatore e/o un ricevitore a seconda del modello.



Indic. dimensions	80x40x60 cm
Indic. weight	220 - 300 kg
Input	24V Dc
Total consumption	14W
Luminous flux	210 Lm
CCT	3.100K
IP rating	IP67
Audio technical data	220W Rms@8Ω
Audio frequency range	45 - 20.000 Hz

*Menhir Sound Pro is a powerful and vibrant outdoor speaker with a 220W audio system and integrated woofer to emphasise bass tones, capable of filling gardens, terraces and open spaces with intense, controlled sound, without visible speakers. Its iconic shape, hand-carved in marble, combines design, audio technology and lighting, giving character and prestige to outdoor spaces. Compatible with apps and home automation systems, it offers customisation options in terms of marble choice. Each piece is unique, powerful and recognisable.*

*To operate the audio speakers, you will need an amplifier and/or receiver, depending on the model.*

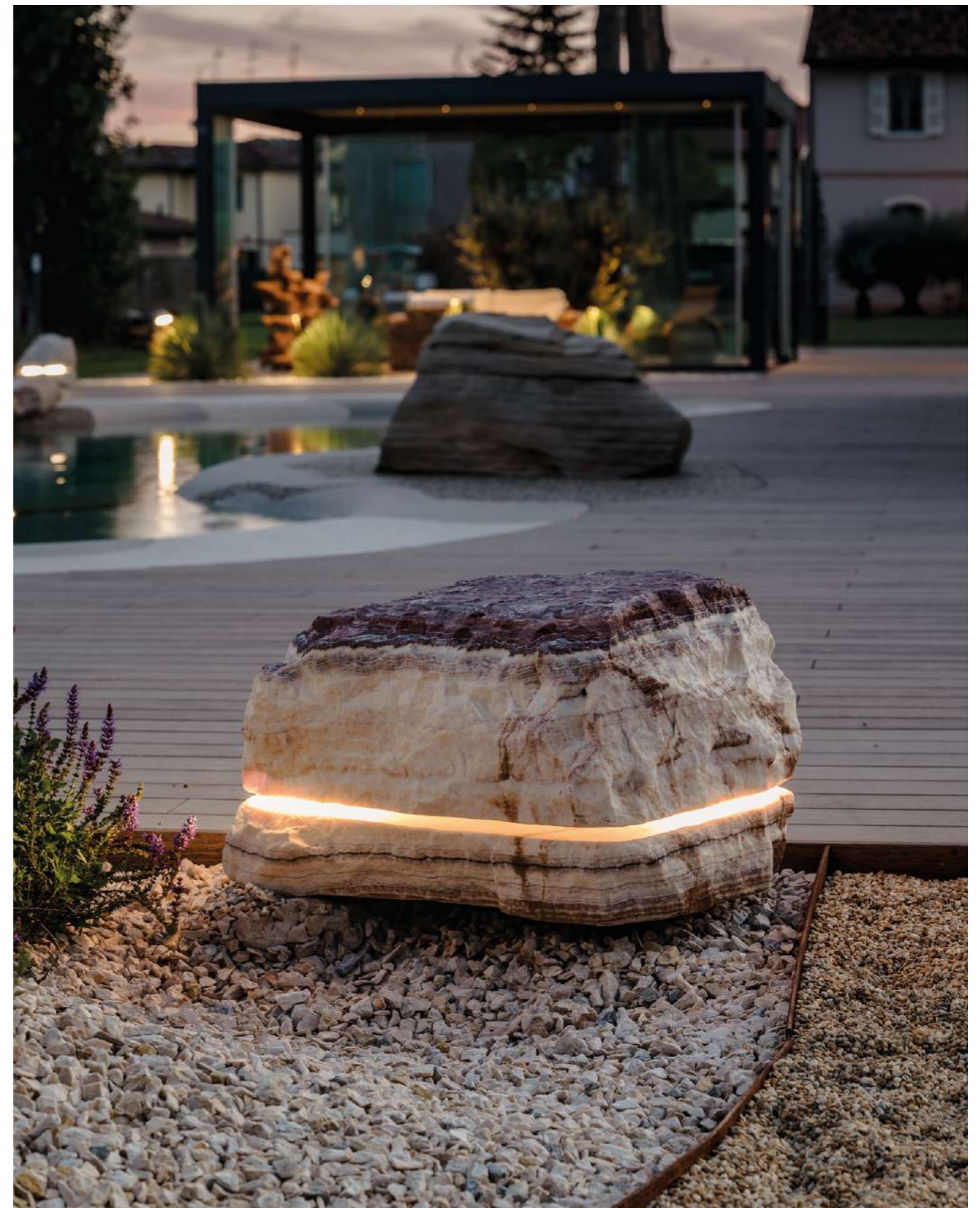
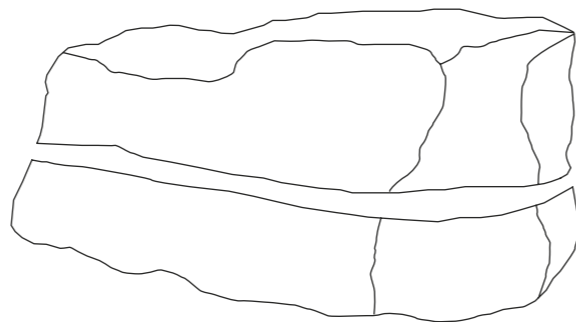



### Lente acustica 30W 30W acoustic lens

Progettata e realizzata in Italia, diffonde il suono a 360° con toni medi e alti chiari e dettagliati. Struttura in acciaio inox AISI 316L, installata all'interno della pietra, ideale per musica di sottofondo.

*Designed and made in Italy, it delivers 360° sound with clear and detailed mid and high frequencies. Structure in AISI 316L stainless steel, installed inside the stone, ideal for background music.*



### Piastra audio Pro 220W 220W Pro audio plate

Integra lente acustica e woofer dedicato, differenziando gli altoparlanti per le basse e le medio-alte frequenze. Suono potente, bilanciato e immersivo. Massima resistenza agli agenti atmosferici.

*Combines an acoustic lens with a dedicated woofer, separating low and mid-high frequencies. Powerful, balanced and immersive sound. Maximum resistance to weather conditions.*

### Identità Identity

Ogni Menhir è scolpito a mano da blocco di marmo naturale e numerato singolarmente, valorizzando le venature e l'unicità della pietra.

*Each Menhir is hand-carved from a natural marble block and individually numbered, highlighting the stone's unique veining and character.*



### Resistenza estrema Extreme resistance

Struttura in acciaio inox, altoparlanti tropicalizzati e lente rivolta verso il basso proteggono da sporco, insetti e condizioni climatiche estreme.

*Stainless steel structure, tropicalized speakers and a downward-facing lens protect against dirt, insects, and extreme weather conditions.*

### Luce e audio indipendenti Divided lighting and audio systems

Sistemi luce e audio separati e indipendenti, utilizzabili insieme o singolarmente secondo l'atmosfera desiderata.

*Light and audio systems are separate and independent, designed for use together or individually according to the desired atmosphere.*

Nota: tutti i sistemi audio necessitano di driver e amplificatori per essere messi in funzione.  
*Note: all audio systems require drivers and amplifiers to run.*



### Luce a tutto tondo All-round light

LED continuo a 360° in struttura di alluminio, resinato per resistenza agli agenti atmosferici ed emissione uniforme e costante della luce.

*Continuous 360° LED in an aluminium structure, resin-sealed for weather resistance and a uniform, consistent light output.*



### Controllo musicale Music playback

Musica gestibile da smartphone via app o integrabile a sistemi audio preesistenti per massima personalizzazione.

*Music can be controlled via smartphone app or integrated with existing audio systems for maximum customization.*

### MENHIR SOUND



Italian Flowery Grey



Trani



Angel Sparks\*



Artic Green\*



Ciottolone Bianco\*



Ocean Blue\*



Legno Fossile\*

### MENHIR SOUND MINIMAL



Italian Flowery Grey



Travertino Ivory



Verde Chalet



Bianco Carrara

### MENHIR SOUND PRO



Italian Flowery Grey



Trani



Angel Sparks\*



Artic Green\*



Legno Fossile\*

\* Texture custom su richiesta | Custom textures on request



# ITALIAN FLOWERY GREY

DISPONIBILE PER | AVAILABLE ON

- MENHIR DI LUCE
- MENHIR MINIMAL
- STAKE
- SOL
- FOCUS
- FLOR
- MENHIR SOUND
- MENHIR SOUND MINIMAL
- MENHIR SOUND PRO



Marmo italiano estratto in Friuli-Venezia Giulia dai toni leggeri che vanno dal bianco al grigio chiaro, con venature color avorio, grigio e rosate. È un materiale estremamente resistente e adatto a contesti architettonici dagli stili diversi.

*Italian marble quarried in Friuli-Venezia Giulia with light tones varying from white to light grey, with ivory, grey and pink veins. It is an extremely resistant material suitable for different architectural styles.*

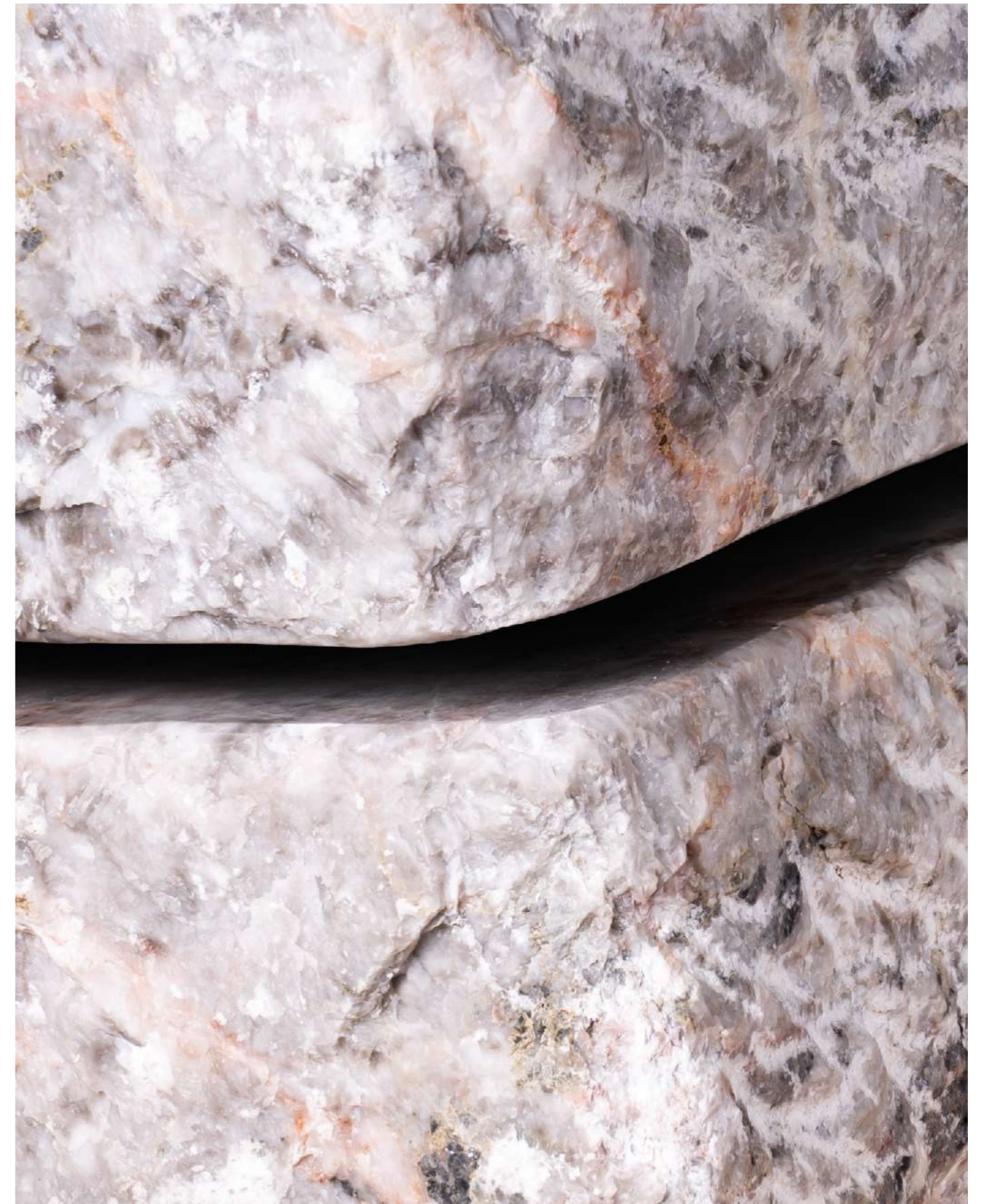

# ANGEL SPARKS

DISPONIBILE PER | AVAILABLE FOR

MENHIR DI LUCE  
STAKE  
SOL  
FOCUS  
FLOR  
MENHIR SOUND  
MENHIR SOUND PRO



Onice estratto in Turchia dal colore beige dorato con venature rosso e arancio scure. Questa particolare texture può presentare cavità e differenti pattern di colore a seconda del taglio. Adatto per chi cerca un marmo che sappia distinguersi.

*Onyx quarried in Turkey with a golden beige colour and dark red and orange veins. This particular texture may feature cavities and different colour patterns depending on the cut. Suitable for those looking for a marble that really stands out.*

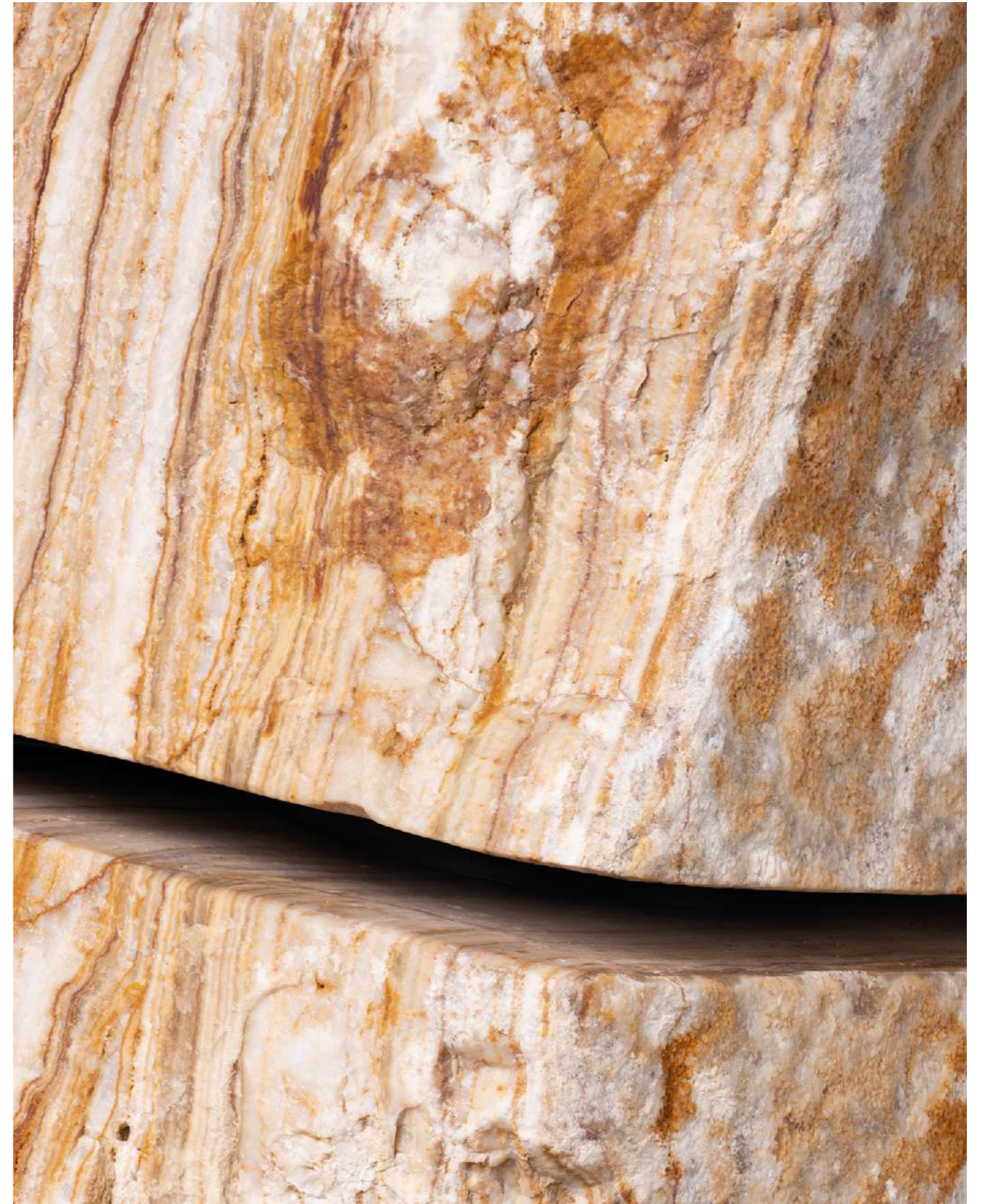

# TRAVERTINO IVORY

DISPONIBILE PER | AVAILABLE FOR

MENHIR MINIMAL  
SOL  
FOCUS  
FLOR  
MENHIR SOUND MINIMAL



---

Roccia iconica dell'architettura romana dai toni caldi della sabbia, dell'avorio e del grigio. Il taglio a vena mostra gli strati di travertino che si sono formati nei millenni ed è caratterizzato da buchi e depressioni naturali sulla superficie.

---

*An iconic stone used in Roman architecture, with warm shades of sand, ivory and grey. The vein cut reveals the layers of travertine that have formed over thousands of years and is characterised by natural holes and depressions on the surface.*



# ARTIC GREEN

DISPONIBILE PER | AVAILABLE FOR

MENHIR DI LUCE  
SOL  
FOCUS  
FLOR  
MENHIR SOUND  
MENHIR SOUND PRO



---

Particolare tipologia di quarzo estratto in Norvegia. Il colore verde si esprime in tutte le sue gradazioni, dalla più chiara alla più intensa. Con la sua struttura nuvolata, dona agli spazi un aspetto elegante anche grazie agli innumerevoli cristalli presenti al suo interno.

---

*A distinctive type of quartz quarried in Norway. The green colour is expressed in all its shades, from the lightest to the most intense. With its cloudy structure, it gives any space an elegant appearance, thanks also to the countless crystals contained within it.*

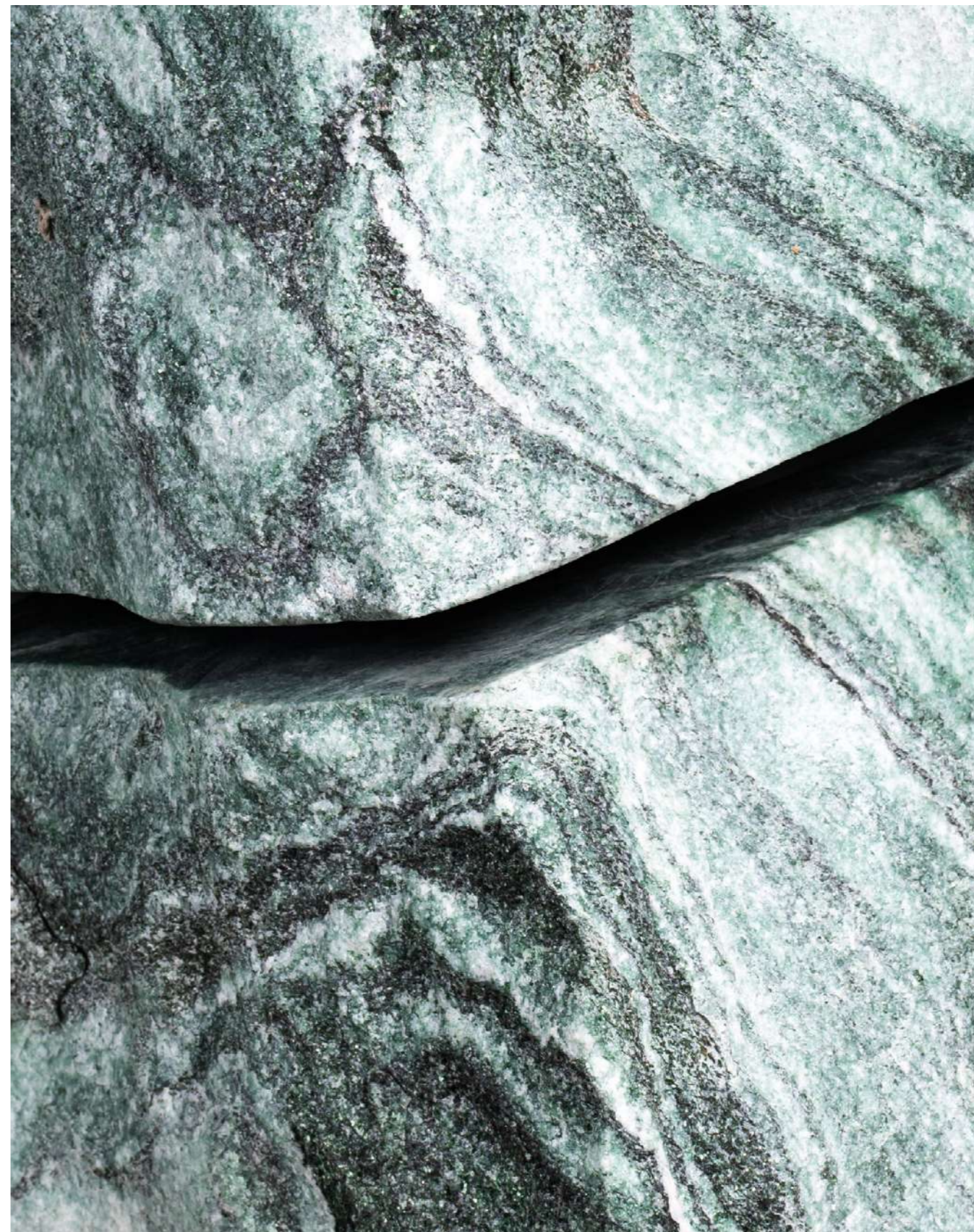

# BIANCO DI CARRARA

DISPONIBILE PER | AVAILABLE FOR

MENHIR MINIMAL  
RAY  
STAKE  
MENHIR SOUND MINIMAL



Tipologia di Bianco di Carrara, marmo italiano estratto nelle cave sulle Alpi Apuane, che presenta un color bianco scuro di fondo con venature grigiastre, talvolta tendenti al nero. Grazie alla sua grana medio-fine, presenta una superficie liscia priva di cavità, perfetta per una lavorazione levigata.

*A type of Carrara White, Italian marble extracted from quarries in the Apuan Alps, which has a dark white background with greyish veins, at times tending towards black. Thanks to its medium-fine grain, it has a smooth surface without cavities, perfect for polished finishes.*

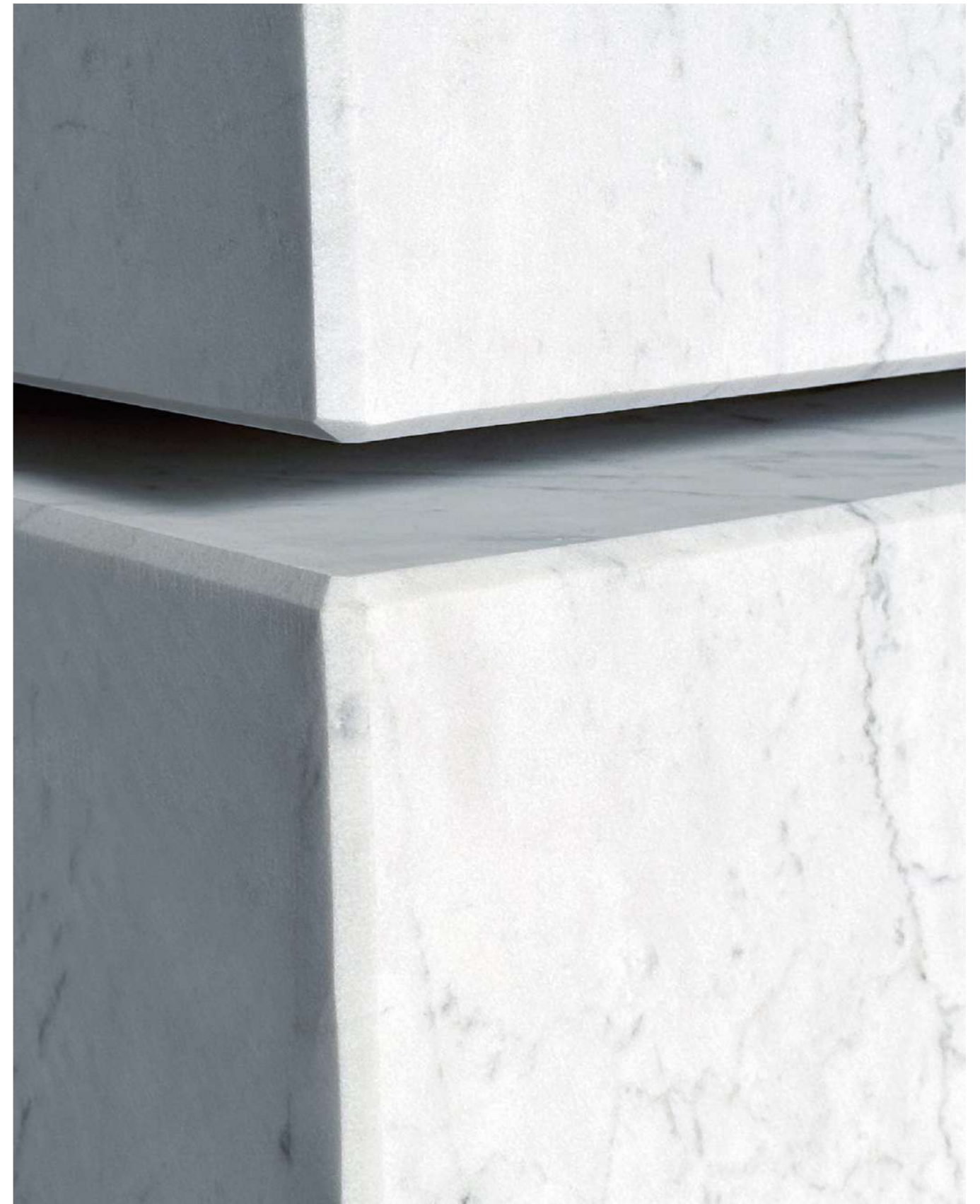



# TRANI

DISPONIBILE PER | AVAILABLE FOR

- MENHIR DI LUCE
- STAKE
- MENHIR SOUND
- MENHIR SOUND PRO

---

Il Marmo Trani è una roccia carbonatica a grana fine estratta in Puglia originata dalla sedimentazione di falde rocciose, di colore avana beige, perfetta per ambienti dallo stile mediterraneo.

---

*Trani marble is a fine-grained carbonate rock quarried in Apulia, southern Italy. It originates from the sedimentation of rock layers in a beige-brown colour, making it perfect for Mediterranean-style environments.*



# VERDE CHALET

DISPONIBILE PER | AVAILABLE FOR

- MENHIR MINIMAL
- STAKE
- MENHIR SOUND MINIMAL

---

Pietra naturale italiana dal fondo verde scuro intenso, attraversata da venature bianche irregolari che ne esaltano il dinamismo. Compatta e resistente agli agenti esterni, garantisce elevate prestazioni nel tempo. La sua struttura la rende adatta a lavorazioni geometriche e squadrate.

---

*Italian natural stone with a deep dark green background, crossed by irregular white veining that enhances its sense of movement. Compact and resistant to weathering, it ensures long-lasting performance over time. Its structure makes it suitable for geometric and squared-cut applications.*





## PIETRA DI LUSERNA

DISPONIBILE PER | AVAILABLE FOR

### STAKE

Pietra gneiss di tipo lamellare, la Pietra di Luserna è composta da strati naturali sovrapposti che ne definiscono la struttura e la resistenza. Originaria del Nord Italia, si distingue per un'elevata robustezza e per il suo caratteristico colore grigio tenue, attraversato da venature naturali azzurre generate dalla presenza del quarzo all'interno della pietra.

*A lamellar gneiss rock, Luserna Stone is composed of overlapping natural layers that define its structure and resistance. Originally from Northern Italy, it is distinguished by its high strength and characteristic soft grey colour, crossed by natural blue veins generated by the presence of quartz within the stone.*



## ARDESIA BLACK PILLAR

DISPONIBILE PER | AVAILABLE FOR

### STAKE

Estratta nella Penisola Iberica, è una roccia di origine sedimentaria, resistente e compatta. Di colore grigio-nero, a contatto con l'ossigeno e con l'umidità si ossida: grazie all'alta concentrazione di metalli presenti al suo interno, da vita a finiture corten-ruggine estremamente caratteristiche.

*Quarried in the Iberian Peninsula, this is a resistant and compact sedimentary rock. Grey-black in colour, it oxidises on contact with oxygen and moisture: thanks to the high concentration of metals present within it, it produces extremely characteristic corten-rust finishes.*





## CIOTTOLONE BIANCO

DISPONIBILE PER | AVAILABLE FOR

MENHIR DI LUCE  
MENHIR SOUND

---

Marmo di origine spagnola, caratterizzato dalla presenza di cristalli di grandi dimensioni e da una struttura priva di impurità visibili. La sua superficie richiama l'aspetto dello zucchero bianco cristallizzato, conferendo al materiale un'elevata riflettanza e una forte purezza visiva.

---

*Marble of Spanish origin, characterised by the presence of large crystals and a structure with no impurities. Its surface resembles crystallised white sugar, giving the material high reflectance and strong visual pureness.*

## OCEAN BLUE

DISPONIBILE PER | AVAILABLE FOR

MENHIR POOL  
MENHIR SOUND

---

Ocean Blue è un basalto di origine francese, caratterizzato da una texture blu-grigio naturalmente macchiata di bianco e, in casi particolari, da leggere inclusioni gialle. Grazie alla sua elevata resistenza e compattezza, è particolarmente indicato per l'immersione in acqua clorata o salata, mantenendo inalterate le proprie caratteristiche nel tempo.

---

*Ocean Blue is a French basalt, characterised by a blue-grey texture naturally stained with white and, in some cases, light yellow inclusions. Thanks to its high resistance and compactness, it is particularly suitable for immersion in chlorinated or salt water, maintaining its characteristics over time.*

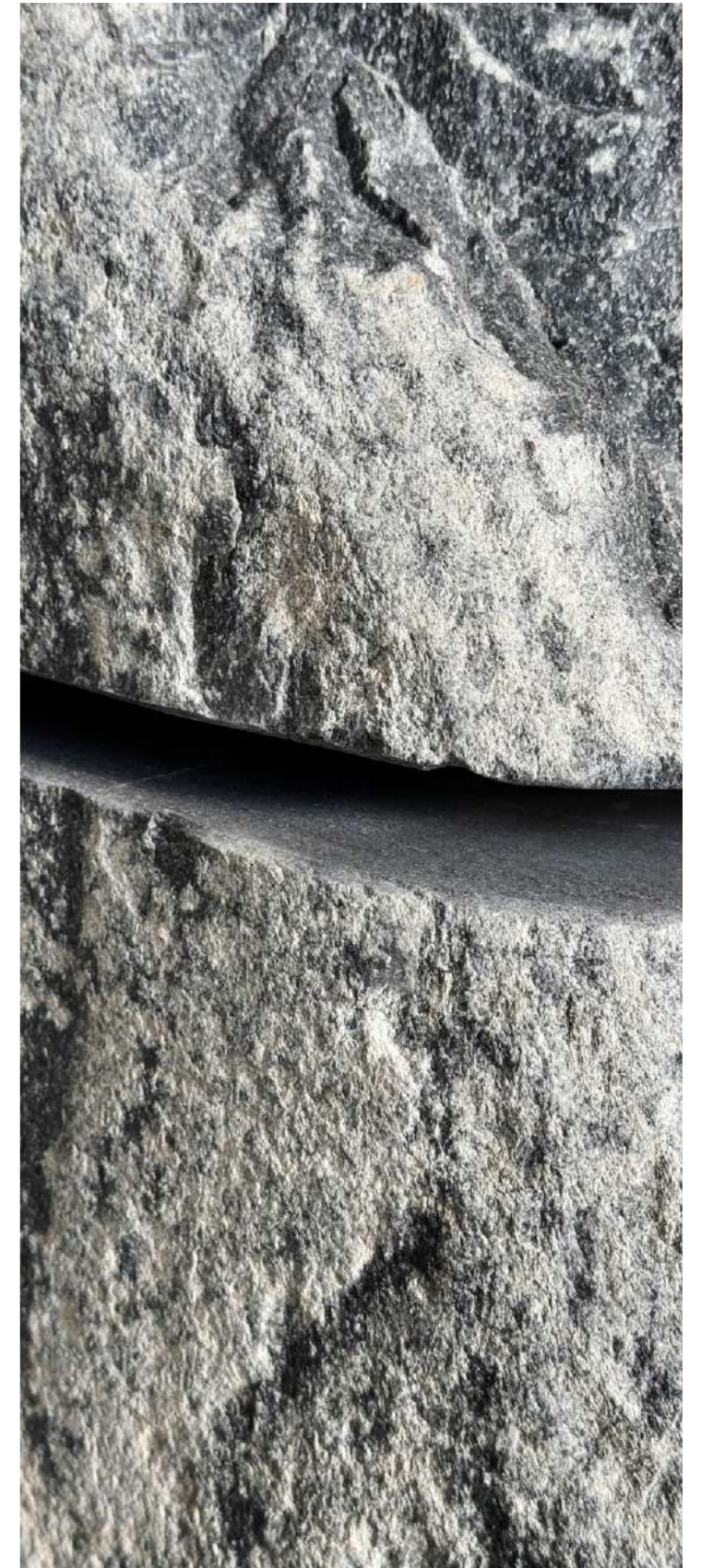



## LEGNO FOSSILE PETRIFIED WOOD

DISPONIBILE PER | AVAILABLE FOR

MENHIR SOUND  
MENHIR SOUND PRO

---

Originario delle foreste dell'Amazzonia, è un legno pietrificato in cui la parte organica è sostituita da minerali, mantenendo tuttavia la struttura esterna originale del legno. Questa pietra naturale cambia leggermente il suo colore poiché assume le tonalità dei minerali presenti nella terra in cui si trova.

---

*Originating from the Amazon rainforest, this is petrified wood in which the organic part has been replaced by minerals over time, while retaining the original external structure of the wood. This natural stone changes colour slightly as it takes on the shades of the minerals present in the earth in which it is found.*

## VERDE ALPI GIALLO MORI NERO EBANO

DISPONIBILE PER | AVAILABLE FOR

RAY

---

Il marmo Verde Alpi, originario delle Alpi Occidentali, presenta una struttura stratificata in diverse tonalità di verde attraversate da venature bianche, che ne esaltano eleganza e raffinatezza.

Il Giallo Mori, estratto nel Nord Italia, è un marmo a grana compatta dal fondo giallo intenso attraversato da sottili venature color ruggine, apprezzato per l'elevata resistenza, anche alle basse temperature.

Il Nero Ebano è una pietra naturale italiana dal nero profondo e uniforme. Proveniente dal Nord Italia, in area bergamasca, unisce compattezza e resistenza agli agenti atmosferici.

---

*Verde Alpi marble originates in the Western Alps and features a layered structure in varying shades of green crossed by white veining, enhancing its elegance and refinement.*

*Quarried in Northern Italy, Giallo Mori is a compact-grained marble with a deep yellow background crossed by fine rust-coloured veining, valued for its high resistance, even to low temperatures.*

*Nero Ebano is an Italian natural stone with a deep and uniform black tone. Sourced from Northern Italy, in the Bergamo area, it combines compactness and resistance to weathering.*





Essenze di Luce srl  
Via dell'Artigianato, 12/2  
33048 San Giovanni al Natisone (UD) Italia  
Telefono: +39 0432 756612  
E-mail: [info@essenzediluce.com](mailto:info@essenzediluce.com)

Fotografie: Elisa Fedrizzi | Flavio Graffi | Luca Defant  
Impaginazione grafica: Opra Studio di Joanne Marie Lucie Mezzarobba  
Stampa: Grafiche Manzanese 1974

Immagini a scopo illustrativo. Eventuali variazioni di colore, venature e texture sono caratteristiche intrinseche del materiale.  
*Images are for illustrative purposes only. Variations in color, veining and texture are inherent characteristics of the material.*